

m.look Exterior Technique



For you to create



Fundermax

[www.fundermax.com](http://www.fundermax.com)



Keeps what it promises.



## Contents

Qualifications	4
Environment	6
General	8
Specifications	10
Function und advantages	12
Facade	14
Soffits	22
Balconies and Railings	26
Balcony divider panels	30
Perforations by m.look	34
Recommendations for working	36
Recommendations for mounting	42
Cleaning	48
Accessories and Suppliers	50

## **Fundermax**

From furniture and facades to interior design, Fundermax is at the interface of ideas and materials. Today the company – which has a proud history spanning 130 years – stands as a global market leader and producer of high quality materials using wood and laminates. Our lasting success has been based on high quality, imaginative design, diversity and sustainable production. Our products are “Made in Austria” and exude a love for the natural resources of wood, creativity and inventiveness.

- modern production facilities in Austria and Norway
- approx. 1,500 employees
- annual turnover of €500 million
- part of Constantia Industries AG
- The Austrian Excellence Award (2018)

# 1 Qualifications

**"The best foundation  
is always the quality."**

(Patricia Z., practice manager)



**Europe**

m.look Exterior panels are Euro Class A2-s1, d0 in accordance with EN 13501-1

**Austria**

Tested in accordance with ÖNORM B3800-5 for vertical facades, slanted facades and soffits.

Requirements regarding fire protection are set out in the national building regulations and the OIB guidelines in the current version. For certain applications, proof of B 3800-5 (facade fire test) is required in addition to proof of Euro Class A2-s1, d0 in accordance with EN 13501-1. For special constructions, we are happy to support you in clarifying and fulfilling the local building regulations.

**Germany**

Technical approval/general design approval from the German Institute for Building Technology (DIBt Berlin). Approval no: Z-10.3-711.

The requirements are set out in the national building regulations and the guidelines for special constructions such as school buildings, high-rise buildings, public buildings, metros, hospitals and airports.

**Switzerland**

Klassifizierung: A2-s1, d0

Current documentation on all standards and approvals relating to m.look panels can be found in the internet at: [www.fundermax.com](http://www.fundermax.com)

Please be certain to observe the applicable building regulations. Fundermax will assume no liability for a failure to do so. Please check whether your construction project meets the requirements for the effective restriction of fire propagation (e.g. AT: OIB RL 2, DE Sample Management Regulations for Technical Building Regulations MVV TB,„). This brochure is intended for professionals who are familiar with the relevant standards, technical regulations, legal requirements and relevant guidelines for building products. These guidelines have been prepared with great care, but we would like to point out that the responsibility for the correct planning always lies with the planner and the responsibility for correct installation always lies with the installer.

## 2 Environment

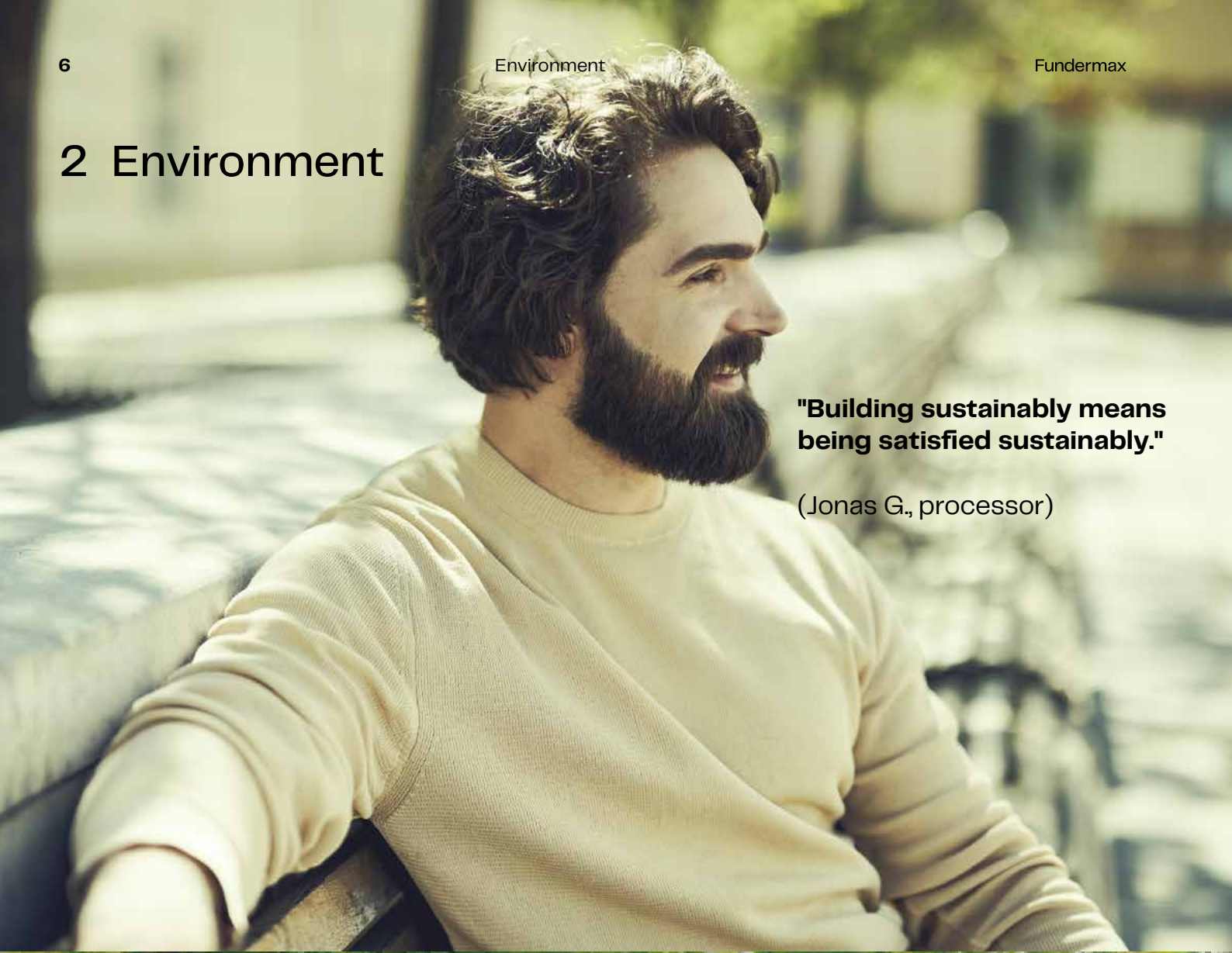

**"Building sustainably means being satisfied sustainably."**

(Jonas G., processor)



### Environmentally Friendly Production

The glass veil is impregnated with resins in impregnation lines, dried and pressed under high pressure and heat into durable moisture resistant panels. The exhaust air extracted during the drying is treated by regenerative thermal oxidation and the resulting heat is again reintroduced into the process.

Fundermax received the „climate:active“ award as best practice from the Austrian Energy Agency and the Federal Ministry for the Environment for the installation of this efficient air treatment system. The production plant can thus reduce its emissions by approximately 10,000 tons of CO<sub>2</sub> per year.

### Natural Resources

Fundermax m.look panels consist mostly of natural mineral resources that are available in unlimited quantities. Glass fibers give the panel the necessary strength and the proven resins make it moisture resistant and durable.

### Durable and Maintenance-free

Extensive tests certify the exceptional durability of Fundermax m.look panels. The production process ensures a highly resistant surface. Fundermax m.look panels do not require any maintenance to ensure a long service life. The surface of the panels is highly resistant to soiling. If necessary, they can be cleaned with standard cleaning agents. It is not necessary to seal the edges, even after cutting. The edges will take on their natural color after a short period of time.

### Environment

Environmental objectives are fulfilled both for new buildings, as well as for the renovation of existing buildings, through the use of rear-ventilated facades: The measurable reduction in energy required for heating minimizes the carbon dioxide emissions, one of the greatest causes of environmental pollution. State and regional subsidy programs are still available for energy-saving facade renovations.

### Disposal and Recycling

The cuttings or dust from machining can be disposed of just like any other building material. The European waste catalogue applies in EU countries according to the List of Wastes Ordinance. The decision on the six-digit key number to be assigned depends on the origin of the waste. The waste disposal enterprise can assist you in the classification according to the List of Wastes Ordinance.

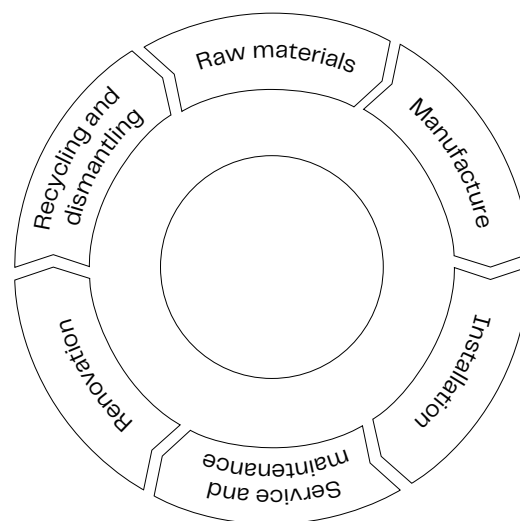

## 3 General

### m.look architectural facade panel (A2)

m.look is an architectural facade panel with heavy duty, reinforced glass fiber, predominantly mineral, non-combustible core with a highly weather resistant decorative surface. The decorative surface is characterized above all by high scratch resistance, light fastness, impact resistance, anti-graffiti properties, ease of cleaning and hail resistance. Properties tested in accordance with EN438-2.

#### Classification

A2-s1, d0 nach EN 13501-1

#### Surface

NT

#### Format

3,580 x 1,580 mm

Tolerances - 0 / +10 mm

Panel dimensions are production dimensions. It is recommended to cut all sides of the panel if precise dimensions and angles are required. Depending on the cut, the net dimensions are reduced by approx. 10 mm.

#### Thickness

7.0 mm

Tolerance: +0.8 / -0.4 mm

9.0 mm

Tolerance: +0.8 / -0.5 mm

Panels with double-sided decorative design.

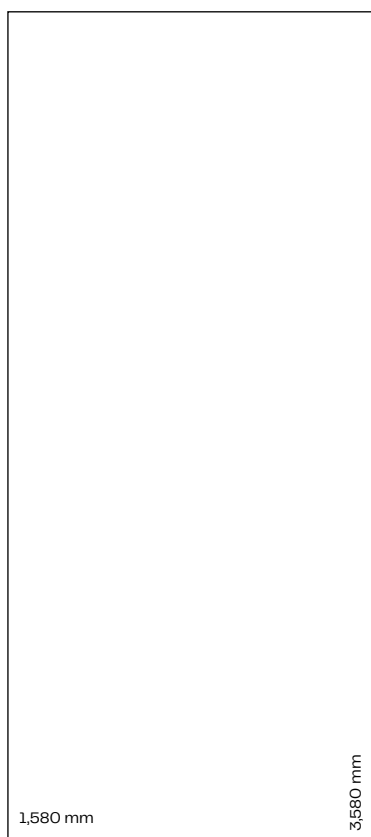



### Material Properties

m.look panels shrink when they release moisture!  
m.look panels expand when they absorb moisture!  
When working with and using m.look panels in construction, these possible dimensional changes must be taken into consideration.

In this context, please note the realisation of fixed and sliding points during panel installation. Where m.look panels are connected to one another, they must follow the same panel direction.

The dimensional change for m.look panels is generally about 30% less in the longitudinal direction than it is in the transverse direction (longitudinal direction relative to the standard panel dimensions).

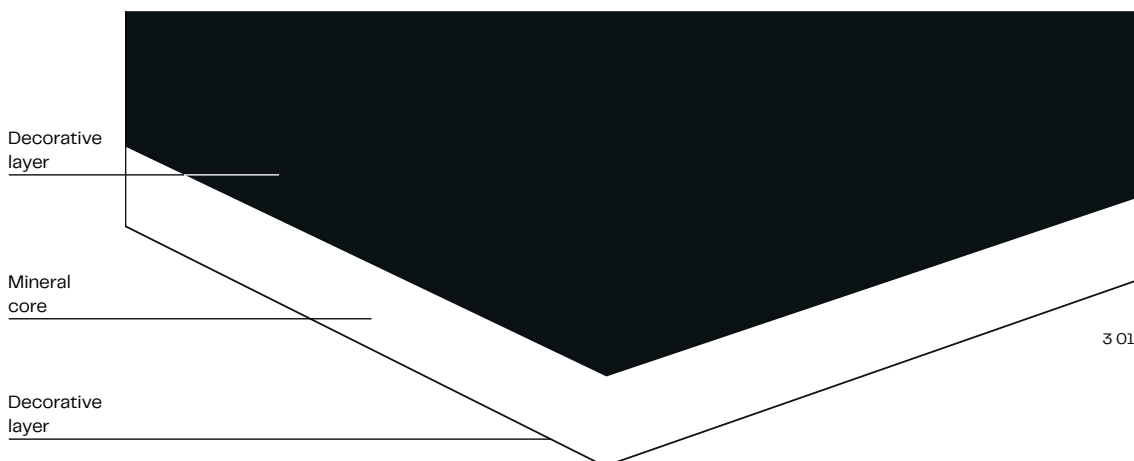

## 4 Specifications

Panel Dimensions	Test Method	Tolerance	Values	Unit
Length		- 0 / +10	3,580	mm
Width		- 0 / +10	1,580	mm
Strength		+ 0.8 / -0.4 + 0.8 / -0.5	7,0 9,0	mm
Flatness	EN 438-6/5.3	≤ 5	≤ 5	mm/m

Types	Test Method	Tolerance	Values	Unit
Decors			based on the current range of decors	
Special decors			on request	
Cut length/width		+ 0.5		mm
Machining (drilling, milling, CNC)			on request	
Surface texture			NT	
Substructure			aluminium, steel	
Wall anchors			Fassadenniet Alu/Niro K14	
Fastening spacings			up to 800 mm in accordance with the structural standard for the panel type	
Joint width			8 ±1	mm

Physical Properties	Test Method	Standard Value	Values	Unit
Building material class / VKF approval CH	EN 13501-1	-	A2-s1, d0	
Fire resistance	EN ISO 1716	≤ 3*	≤ 3	MJ/kg
Surface protection			Weather protection, consisting of patented, double hardened acrylic polyurethane resin	
Light fastness of the decorative layer (standard)	EN 438-2/29	≥ 3**	≥ 3	Gray scale
Light fastness of the decorative layer (special)	EN 438-2/29	≥ 3**	≥ 4	Gray scale
Scratch resistance (surface hardness)	EN 438-2/25		≥ 3	Degree
Flexural strength	EN ISO 178	-	≥ 38	MPa
E-Module	EN ISO 178	-	≥ 9500	MPa
Basis weight		-	12.6 (7.0 mm) +2 / -1 16.2 (9.0 mm) +2 / -1	kg/m <sup>2</sup>
Density	EN ISO 1183-1	-	≥ 1.8	g/cm <sup>2</sup>
Freeze/thaw cycle test	EN 438-2/19	-	passed	
Resistance to impact (falling ball)	EN 438.2-21	≤ 10**	≤ 10	mm
Thickness swelling 24 hours	EN 317	-	≤ 0.1	%

**Permits**

Facade permit Germany	Institut für Bautechnik Berlin	Approval-Nr. Z-10.3-711
ETB guidelines for building components which safeguard against falls, June 1985. Balcony railings.	ift Rosenheim	9 mm passed (for details on railing constructions, see section 'Balconies and Railings')
WinMark UK	Wintech	A10114

Physical Properties	Test Method	Standard Value	Values	Unit
Formaldehyde emission	ISO 16000 <sup>1)</sup>	≤ 0.1 <sup>***</sup>	≤ 0.1	ppm
VOC emission (TVOC)	ISO 16000 - 3, 6, 9	≤ 1.0 <sup>****</sup>	0	mg/m <sup>2</sup>
Disposal			Same as for other building materials (in Austria key number 91401)	

1) Test report EPH 2515443A1

\* according to EN 13501-1

\*\* according to EN 438-6

\*\*\* according to EN 438-7

\*\*\*\* according to AgBB scheme 2015

For the surface NT applies a gloss degree tolerance of +/- 5 GE measured at 60°. The tolerances information sheet (version 2017-1-16) from the ÖFHF ([www.oefhf.at](http://www.oefhf.at)) shall apply with regard to color tolerance

All the respective current certificates and approvals are available in the download section at [www.fundermax.com](http://www.fundermax.com).

Please observe all valid building regulations. We will assume no responsibility in this regard.

Please check whether your construction project meets the requirements for the effective restriction of fire propagation (e.g. AT: OIB RL 2, DE Sample Management Regulations for Technical Building Regulations MVV TB,...). This brochure is intended for professionals who are familiar with the relevant standards, technical regulations, legal requirements and relevant guidelines for building products. These guidelines have been prepared with great care, but we would like to point out that the responsibility for the correct planning always lies with the planner and the responsibility for correct installation always lies with the installer.

# 5 Function and Advantages

## Function and advantages of a non-bearing, rear-ventilated facade

### Protection against rain

The VHF meets the norms for stress group III in accordance with DIN 4108-3 and is driving-rain proof. The low percentage of moisture absorbed from rain water that does not evaporate through the surface of the facade is quickly removed via the ventilation space between the insulation and the wall cladding (weather protection).

### Insulation

The non-bearing, ventilated facade (VHF) system can be designed for different energy requirements with an individually calculated insulation. Thus, any desired insulation thickness can be used. This means insulation values typical of low-energy, passive-energy or active-energy houses and comply with the current energy savings regulations can easily be achieved.

### Protection against condensation water

The construction of the non-bearing, rear-ventilated facade (VHF) decreases the vapor diffusion resistance from the interior to the exterior of the building: Moisture from the construction or use of the building is removed through the rear-ventilation space. Thus the lasting function of the insulation can be ensured and makes a significant contribution to a pleasant and healthy indoor climate.

### Protection against noise

Depending on the thickness of the insulation layer, dimensions of the panels and the proportion of open joints, noise protection can be increased by up to 14 dB.

5 01

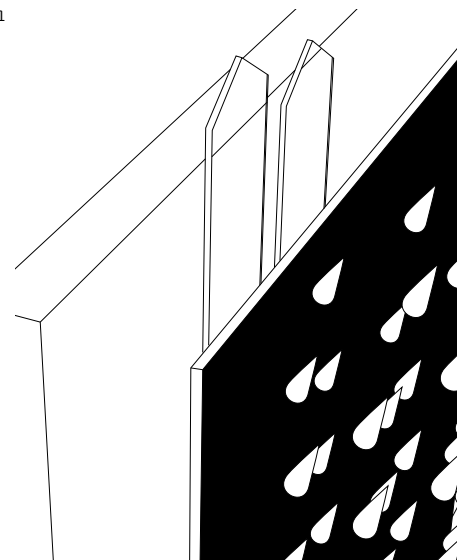

5 02

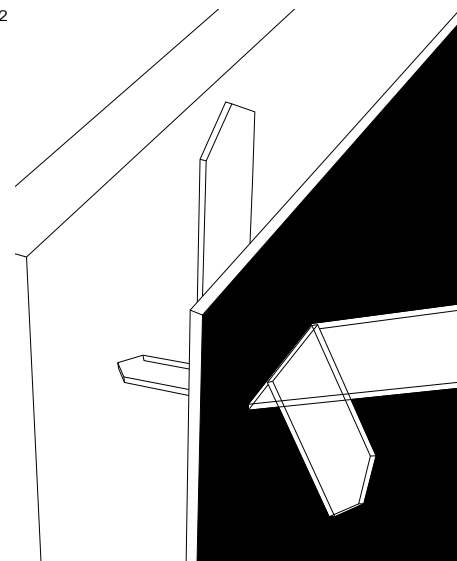

5 03

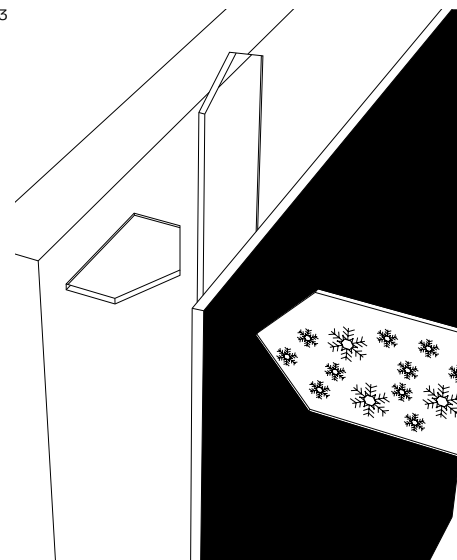

**Economy**

The economic aspects can also be found again in the requirements of sustainable construction: Longevity and long maintenance intervals are the essential key points.

**Cost certainty**

The non-bearing rear-ventilated facades enable exact cost planning, even for renovations.

**General Construction Information**

During construction and installation, make sure that the material is not exposed to standing water, i.e. the panels must always be able to dry. m.look panels may exhibit planar deviations. These should be corrected through a stable, level substructure. All connections to other components or the subsurface are to be force-fitted. Elastic intermediate layers between the panel and the substructure, as well as between parts of the substructure, that allow a tolerance of greater than  $\pm 0.5$  mm are absolutely to be avoided.

Please also see the Tolerances Information Sheet (version 2017-1-16) from the ÖFHF.

Please observe always all valid building regulations.

**Advantages of the non-bearing, rear-ventilated facade**

- Architectural accents can be achieved through various design and joint patterns
- Long-term value retention and appreciation of the building
- Exact cost estimation of the facade
- Long maintenance intervals and low follow-up costs
- Installation under any weather conditions
- Can be installed on virtually any surface
- Savings through the shorter scaffolding times

# 6 Facade

## Installation of m.look panels with rivets on an aluminum substructure.

### Substructure

The aluminum substructure must meet the requirements of the national standards and is to be installed according to the manufacturer specifications for the substructure.

Due to the material properties of m.look panels, fixed points and sliding points need to be made to mount the panels (Fig. 6 03, p. 15). The dimensions of metal substructures vary with changes in temperature. However, the dimensions of m.look panels vary with changes in relative humidity. These dimensional changes in the substructure and wall panel materials may be in opposite directions. It is therefore essential to ensure there is sufficient expansion space when installing m.look panels.

### Rear ventilation regulation

In order to avoid the prolonged formation of condensation in the rear ventilated facade, it is necessary to ensure a constantly functioning ventilation. The free vertical ventilation gap must be at least 200 cm<sup>2</sup>/m and for aluminum substructures a free minimum cross section of 150 cm<sup>2</sup>/m is required for inlet and outlet openings (see ÖNORM B8110-2: 2003).

To enable a vertical flow, the support profiles must always be aligned vertically.

### Sliding point

The drill hole diameter for m.look panels should be 8.5 mm. The head of the fastening means must always cover the hole. The fasteners are to be set such that the panel can move. Rivets must be set centrally using a rivet placement guide. The defined distance of the rivet head to the panel surface (0.3 mm) allows the parts to move in the drill hole (Fig. 6 04, p. 15). The center of the hole in the substructure must line up with the center of the hole in the m.look panel. The appropriate drill guides should be used. The panels should be fastened from the middle outwards.

### Fixed point

Fixed points serve the uniform distribution (halving) of the swelling and shrinkage movements. The drill hole diameter for m.look panels should be 5.1 mm.

Instead of the fix point drill you can use also a fix point socket.

### Loose point

Alternatively the sliding point, situated to the left or right at the same height as the fixed point, can take the form of a loose point. The loose point takes the weight of the panel, along with the fixed point. Swelling and shrinkage movements are not restricted.

### Joint formation

To ensure a tension-free movement of the m.look Exterior panels, the joint formation must be at least 8 mm.

In Germany, the joint formation is defined in accordance with building inspectorate approval Z-10.3-711 with 8 mm.

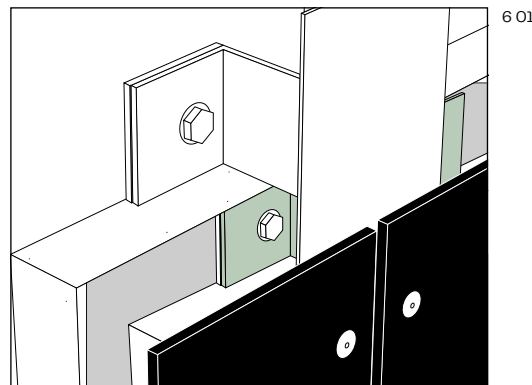

6 02 MBE Fixed-Point Sleeve Set Plus  
Art.No.1240405

Including:  
100 pcs. Fixed-Point Sleeve  $\varnothing$  10 mm  
100 pcs. Floating-Point Sleeve  $\varnothing$  10 mm,  
Slotted Hole 5,2 x 7,7 mm  
(Drill Hole tolerance: 10,0 – 10,03 mm)

#### Note

Please note, when using a Fixed-Point Sleeve with a diameter of 10 mm for Floating-Point fixing, the rivet head must have a diameter of at least 16 mm.

**Fastenings**

Alu-Blind rivet with big color lacquered head.

Rivet sleeve:

Material-No. EN AW-5019

Rivet pin:

Material-No. 1.4541

Pull-off strength of rivet pin: 5.6 kN

Diameter of drill hole in m.look panels:

Sliding points: 8.5 mm

Fixed points: 5.1 mm

Diameter of drill hole in the aluminium substructure:

Sliding points: 5.1 mm

Rivet 5.0 x 16 K14

for support bracket thickness  $2.0 \leq t \leq 3.0$  mm

Rivet 5.0 x 18 K14

for support bracket thickness  $3.0 < t \leq 5.0$  mm

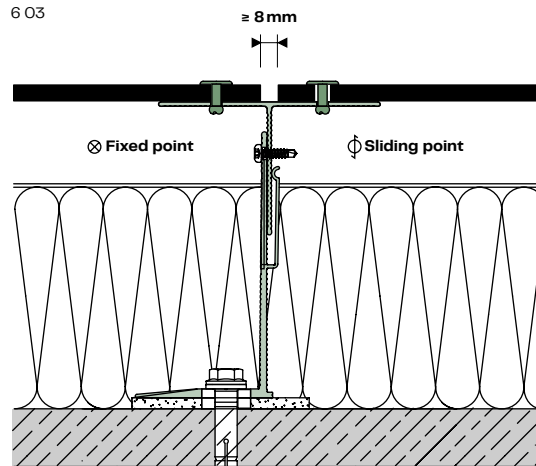

6 04

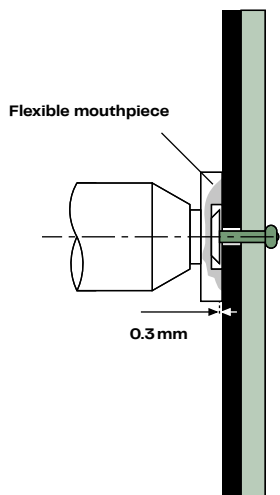

The rivets must be centered and set with a rivet guide with an offset of no more than 0.3 mm.

6 05

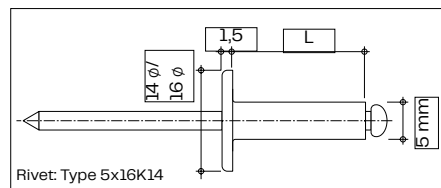

6 06



Instead of a fixed point hole, a fixed point sleeve can also be used.

MBE Art- No. 1240201  $\varnothing$  8.5 mm

MBE Art- No. 1240205  $\varnothing$  10 mm

SFS Art- No. 1240201  $\varnothing$  8.5 mm

- 6 01 Mounting with rivets
- 6 02 MBE Fixed-Point Sleeve Set Plus
- 6 03 Example vertical joint
- 6 04 Clearance 0.3 mm
- 6 05 Aluminium rivet
- 6 06 Fixed-Point Sleeves

6 07

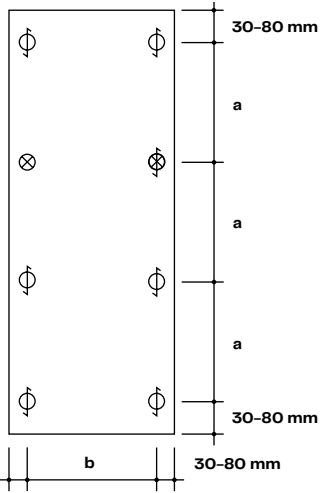

6 08

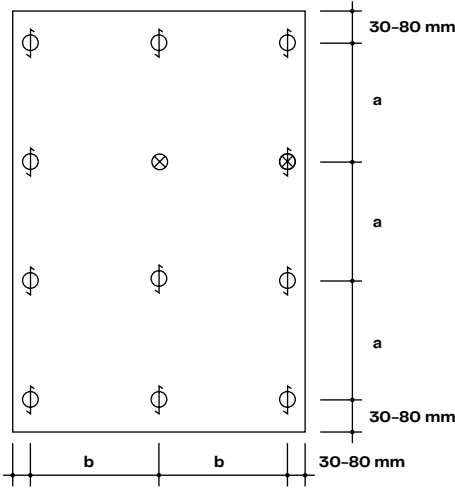

- ⊗ Fix points
- ⊕ Sliding Points
- ⊖ Loose Point

**Edge spacings**

It is absolutely necessary to observe the edge distance in order to ensure stability and flatness (30 - 80 mm).

**Fastening spacings**

The fixing distance is to be selected in accordance with the structural requirements (calculations) or, if this is not necessary due to local building codes, from Tables on page 18 and 19.

6 09

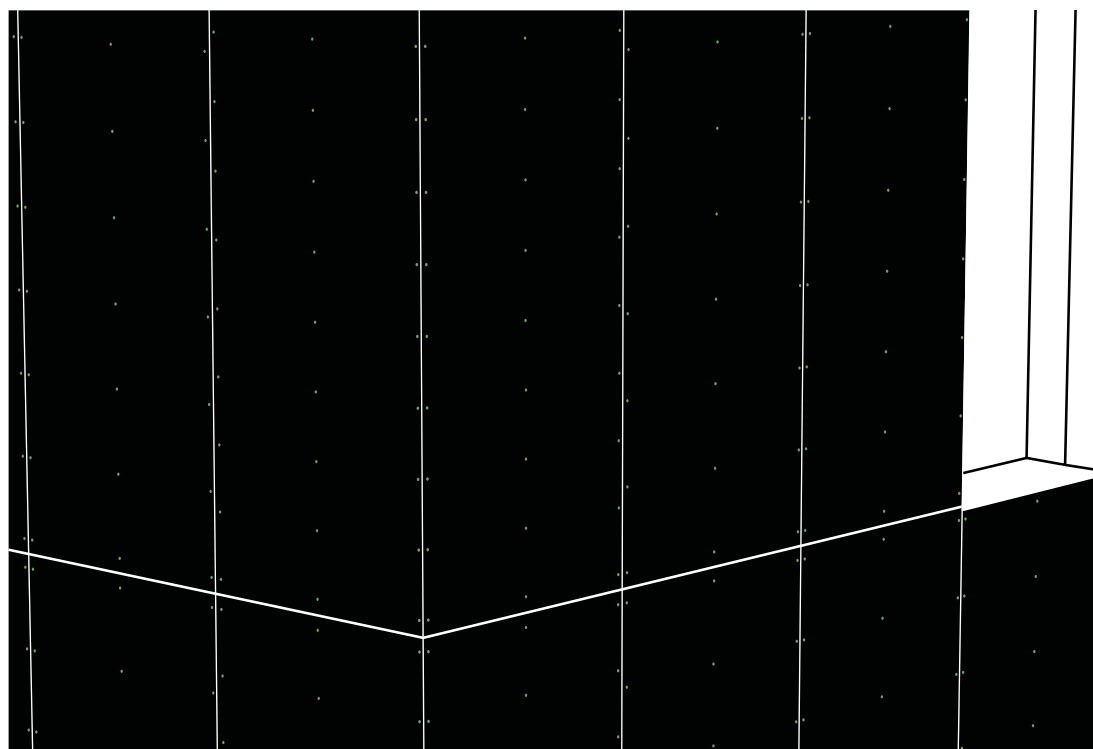

- 6 07 Single span
- 6 08 Multi span
- 6 09 Windlast Eckdarstellung



6 10

**6 10** Project: High school Liefering Austria  
Liefering, Austria  
Planning: Architect DI Johannes Schallhammer

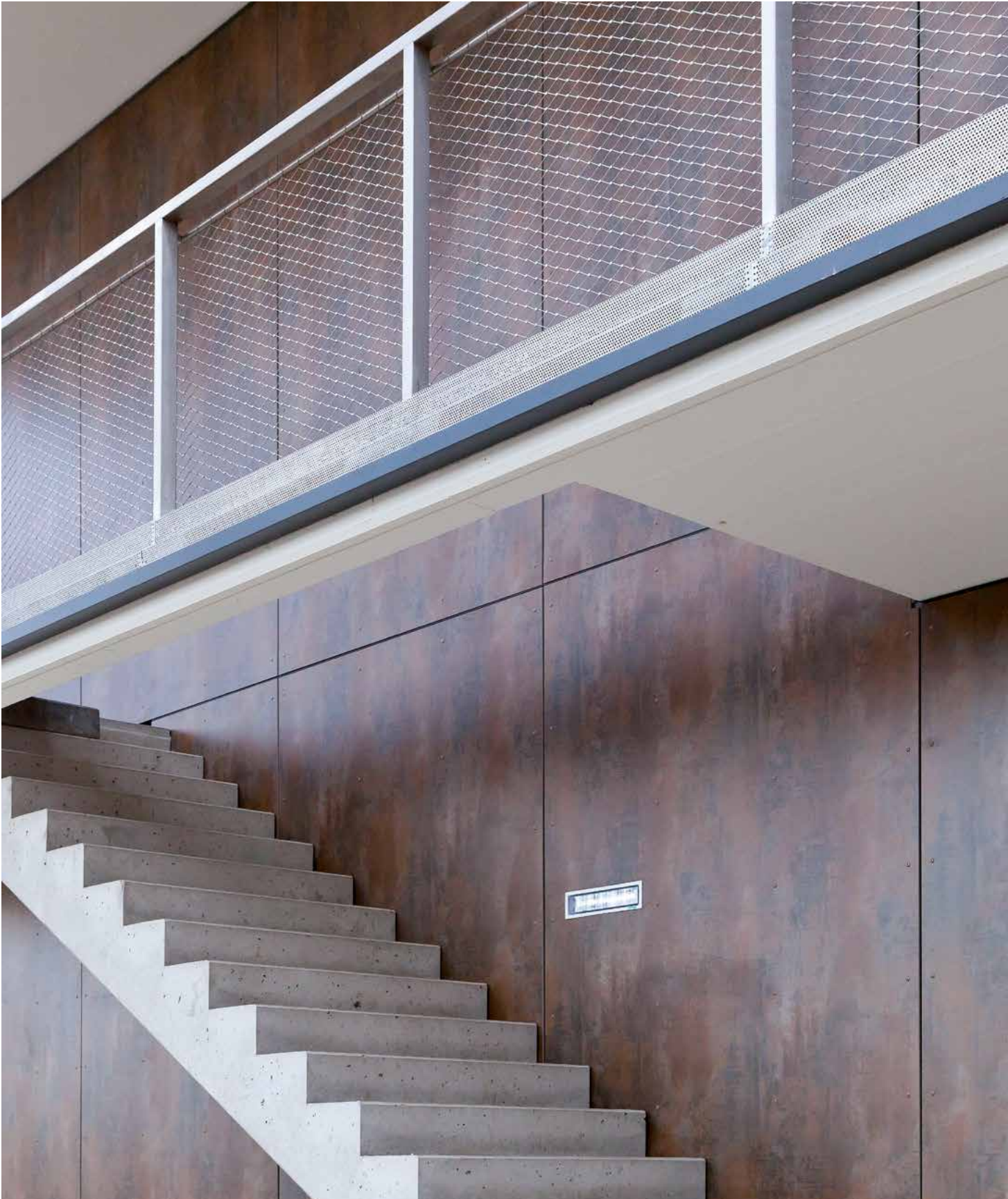

## Wind Loads 7 mm

(A) (CH)

Load chart (wind loads) single span

Load q [kN/m <sup>2</sup> ]	max b [mm]	max a [mm]
0.30	967	967
0.50	851	759
1.00	622	506
1.50	508	405
2.00	440	345
2.50	394	305
3.00	359	275
3.50	333	251
4.00	311	233
4.50	293	217
5.00	278	204

### Fastening spacings

#### for Austria and Switzerland

If the specified axis dimension „b“ is not fully utilized, then the allowable mounting distance „a“ can be calculated as follows (source: Typenstatik m.look Fassadenplatten und m.look Stulpdeckung Dipl.-Ing. Gerald Segeth, Dobel 20.07.19):

$$\text{allow a} = \frac{\text{max b}}{\text{for given b}} * \text{max a}$$

Example:

When installing a double panel with a wind load of 0.5 kN, the following applies: max b = 800 mm and max. a = 573 mm.

If a value of 700 mm is used for „b“ for example, then the maximum allowable „a“ is calculated as follows:

$$\text{allow a} = \frac{800 \text{ mm}}{700 \text{ mm}} * 573 \text{ mm} = 654 \text{ mm}$$

(A) (CH)

Load chart (wind loads) multi span

Load q [kN/m <sup>2</sup> ]	max b [mm]	max a [mm]
0.30	1136	673
0.50	880	521
1.00	622	369
1.50	508	301
2.00	440	261
2.50	394	233
3.00	359	213
3.50	333	197
4.00	311	184
4.50	293	174
5.00	278	165

(A) (CH)

Load chart (wind loads) 3-n-panel

Load q [kN/m <sup>2</sup> ]	max b [mm]	max a [mm]
0.30	1137	735
0.50	960	523
1.00	679	369
1.50	554	302
2.00	480	261
2.50	429	234
3.00	392	213
3.50	363	197
4.00	339	185
4.50	320	174
5.00	304	165

The values in the measurement tables are characteristic values. Dimension tables for the wind load range from 0.3 kN/m<sup>2</sup> to 5.0 kN/m<sup>2</sup> are available upon request from the Fundermax Support Team.

D

Load chart (wind loads) single span

Load q [kN/m <sup>2</sup> ]	max b [mm]	max a [mm]
0.30	800	800
0.50	800	800
1.00	622	506
1.50	508	405
2.00	440	345
2.50	394	305
3.00	359	275
3.50	333	251
4.00	311	233
4.50	293	217
5.00	278	204

D

Load chart (wind loads) multi span

Load q [kN/m <sup>2</sup> ]	max b [mm]	max a [mm]
0.30	800	800
0.50	800	573
1.00	622	369
1.50	508	301
2.00	440	261
2.50	394	233
3.00	359	213
3.50	333	197
4.00	311	184
4.50	293	174
5.00	278	165

D

Load chart (wind loads) 3-n-panel

Load q [kN/m <sup>2</sup> ]	max b [mm]	max a [mm]
0.30	800	800
0.50	800	627
1.00	679	369
1.50	554	302
2.00	480	261
2.50	429	234
3.00	392	213
3.50	363	197
4.00	339	185
4.50	320	174
5.00	304	165

# Constructions–details

## Constructions–details horizontal sections Alu-substructure riveted

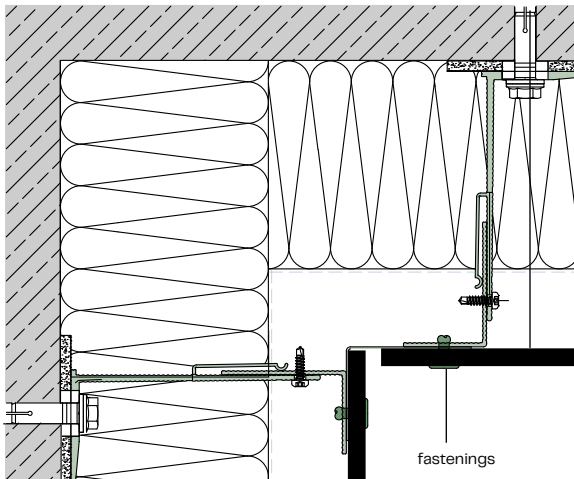

Inner corner A106

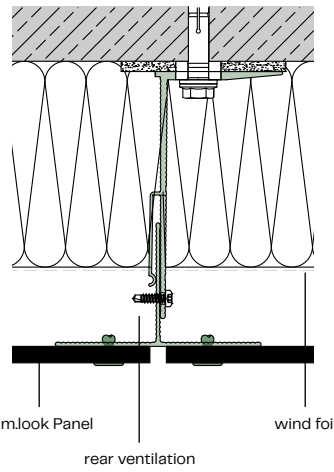

Vertical joint A107

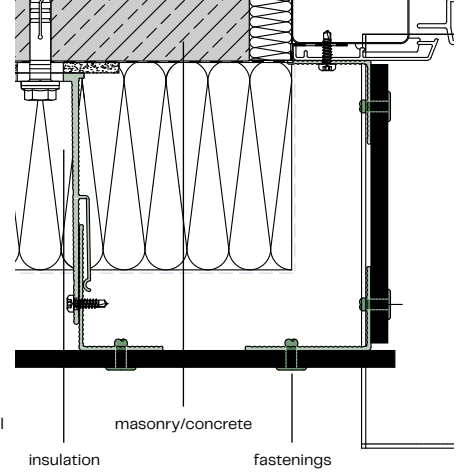

Window reveal A104

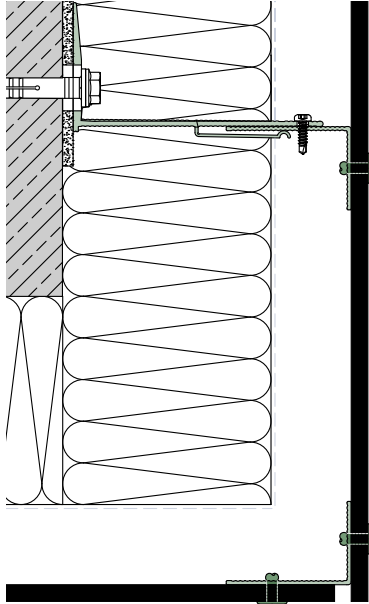

External corner A105

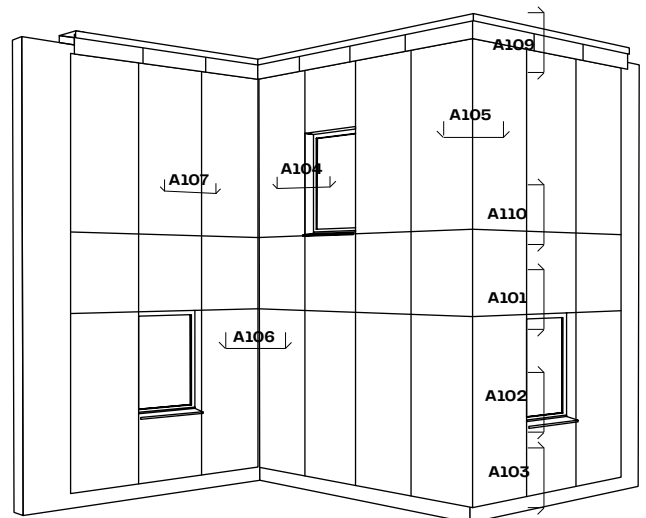

Note:  
All mounting brackets and fastening means shown in this brochure are planning suggestions and are not included with Fundermax panels! All drawings in this brochure are not to scale!

Suppliers: See page 50 at the end of this brochure.

**Constructions—details vertical sections  
Alu—substructure riveted**

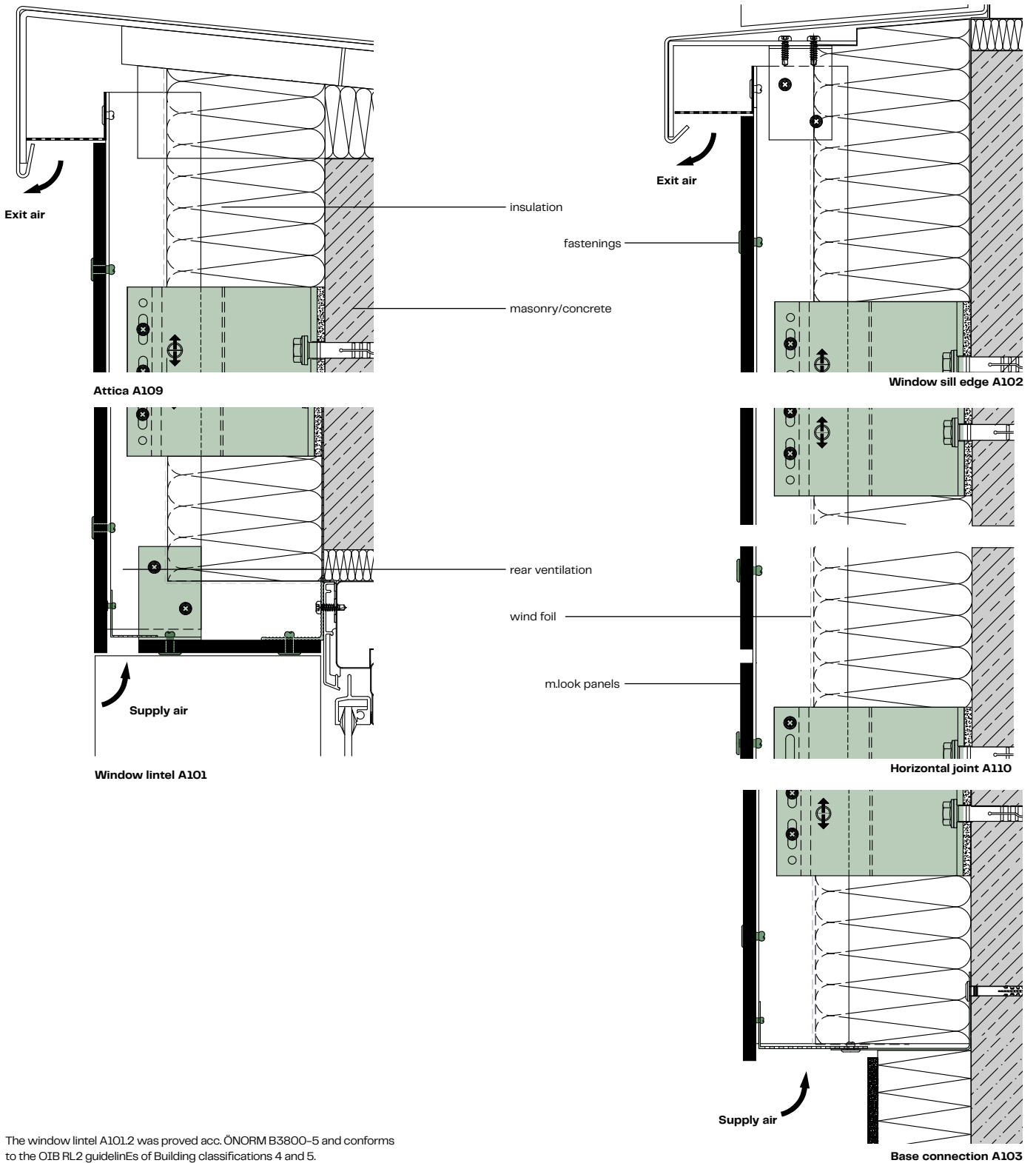

The window lintel A101.2 was proved acc. ÖNORM B3800-5 and conforms to the OIB RL2 guidelines of Building classifications 4 and 5.

# 7 Soffits

## Visible mechanical mounting with rivets as soffit

m.look Exterior panels can be mounted on an aluminium substructure with rivets.

The substructure must always be installed in parallel with the airstream. Inlet and outlet openings must have a free cross-section of at least 150 cm<sup>2</sup>/m. Exit air always leaves via the rear-ventilated section of the rear-ventilated facade.

Connection with EIFS facades are allowed only if these have an exit-air section also. Due to the material properties of m.look Exterior, fixed point and sliding points need to be made to mount the panels.

### Fixed Points

Fixed points are used for uniform distribution (halving) of the expansion and shrinkage movements. The diameter of the drill hole in m.look Exterior has to be same of the diameter of the fastener.

### Sliding Points

The drill hole diameter in the m.look panel must be 8.5 mm. The head of the fastening must cover the drill hole. The fastening is placed in such a way that the panel can move. The rivets must be centred and put in place with a flexible mouthpiece. The defined clearance of the rivet head to the panel surface (0.3 mm) allows movement of the element in the drill hole. The centre of the drill hole in the substructure must coincide with the centre of the drill hole in the m.look panel; suitable drill guides should be used. Fastenings should be put in place starting from the middle of panel outwards.

### Joint Formation

To ensure a tension-free movement of the m.look Exterior panels, the joint formation must be at least 8 mm. In Germany, the joint formation is defined in accordance with building inspectorate approval Z-10.3-711 as 8 mm.

### Edge Spacings

For reasons of stability and flatness, the edge spacings must be kept to without fail.

### Fastening Spacings

These are to be chosen in accordance with the structural engineering requirements (calculations) or, if this is not necessary due to the local regulations, according to the table on page 10.

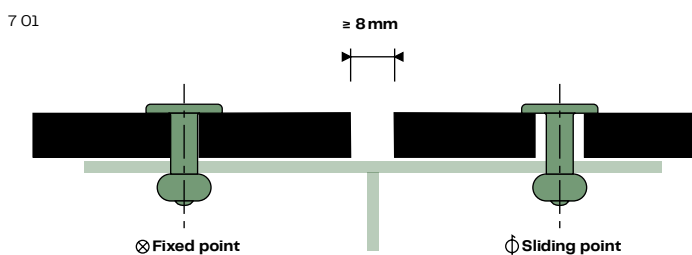

Panel thickness	maximum fastening spacing „b“ single span panel	maximum fastening spacing „a“ multi span panel
7 mm	350 mm	400 mm

7 02

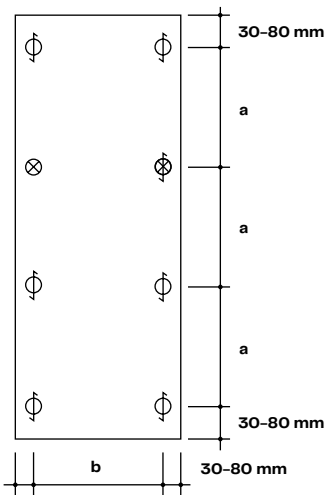

7 03

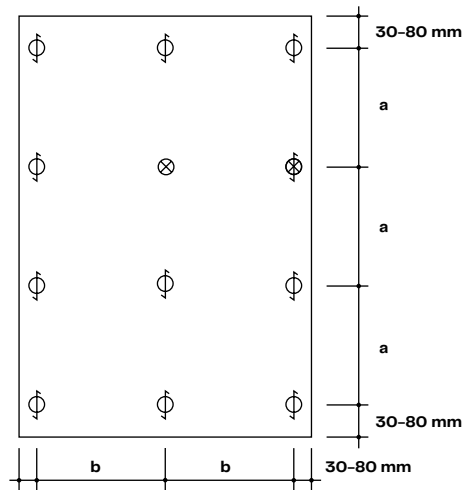

- ⊗ Fixed Point
- ⊕ Sliding Points
- ⊖ Loose Point (alternative)

7 01 Example of vertical joint

7 02 Single span panel

7 03 Multi span panel

### Fastenings

It is essential that fastenings are made from non-corrosive materials.

### Alu-Blind Rivet

(Fig. 6 10, p. 17) with big head colour lacquered for outdoor applications with Max Compact Exterior panels on aluminium-substructures.

Rivet sleeve: material-no. EN AW-5019  
acc. DIN EN 755-2

Rivet pin: steel material-no. 1.4541  
Pull-off strength of rivet pin:  $\approx 5.6$  KN

Rivet 5.0 x 16 K14  
for support bracket thickness  $2.0 \leq t \leq 3.0$  mm  
Rivet 5.0 x 18 K14  
for support bracket thickness  $3.0 < t \leq 5.0$  mm

Approved by DIBt Berlin (approval no. Z-10.3-711)  
for m.look Exterior cladding for external walls.

Diameter of drill hole in m.look Exterior for installation with rivets  
Sliding points: 8.5 mm  
Fixed points: 5.1 mm  
Drill hole diameter in the aluminium substructure 5.1 mm.

The rivets must be put in place with a flexible mouthpiece (Fig. 6 04, p. 15), clearance 0.3 mm. The rivet, flexible mouthpiece and riveting tool must be compatible.

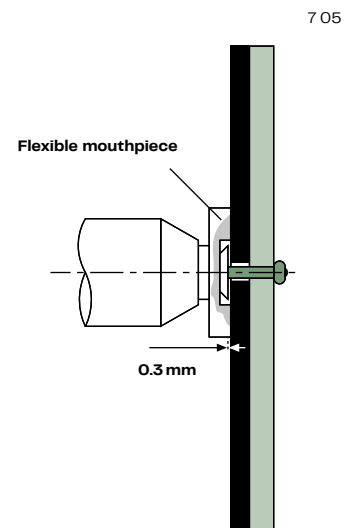
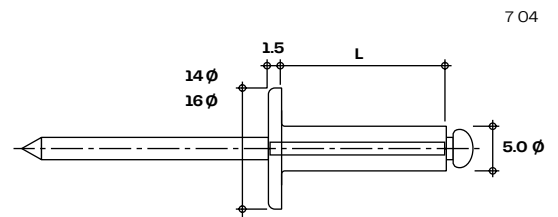



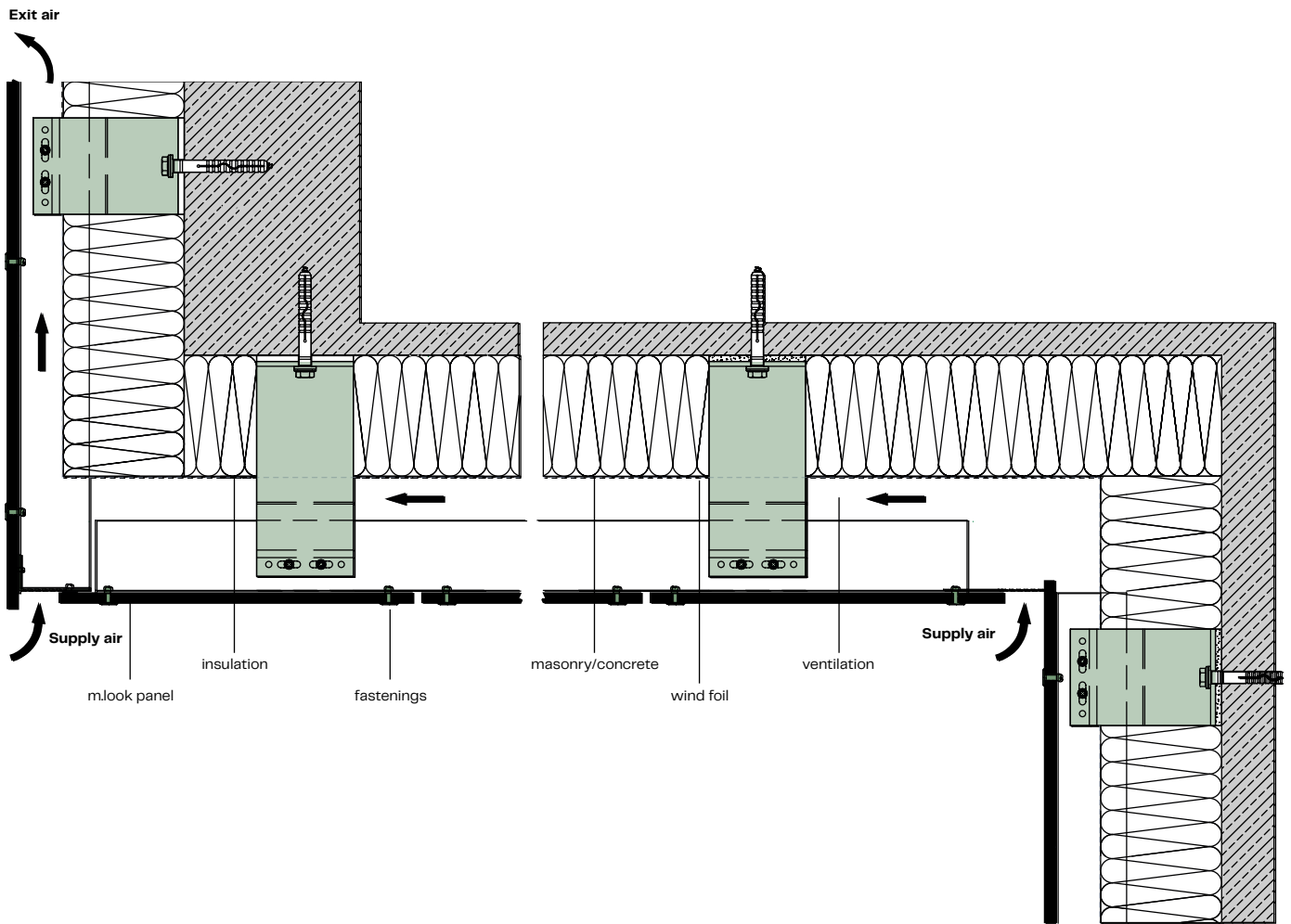

## 8 Balconies and Railings

**„Balconies mean freedom – and that's what you need when designing them.“**

(Isabelle S., project manager)

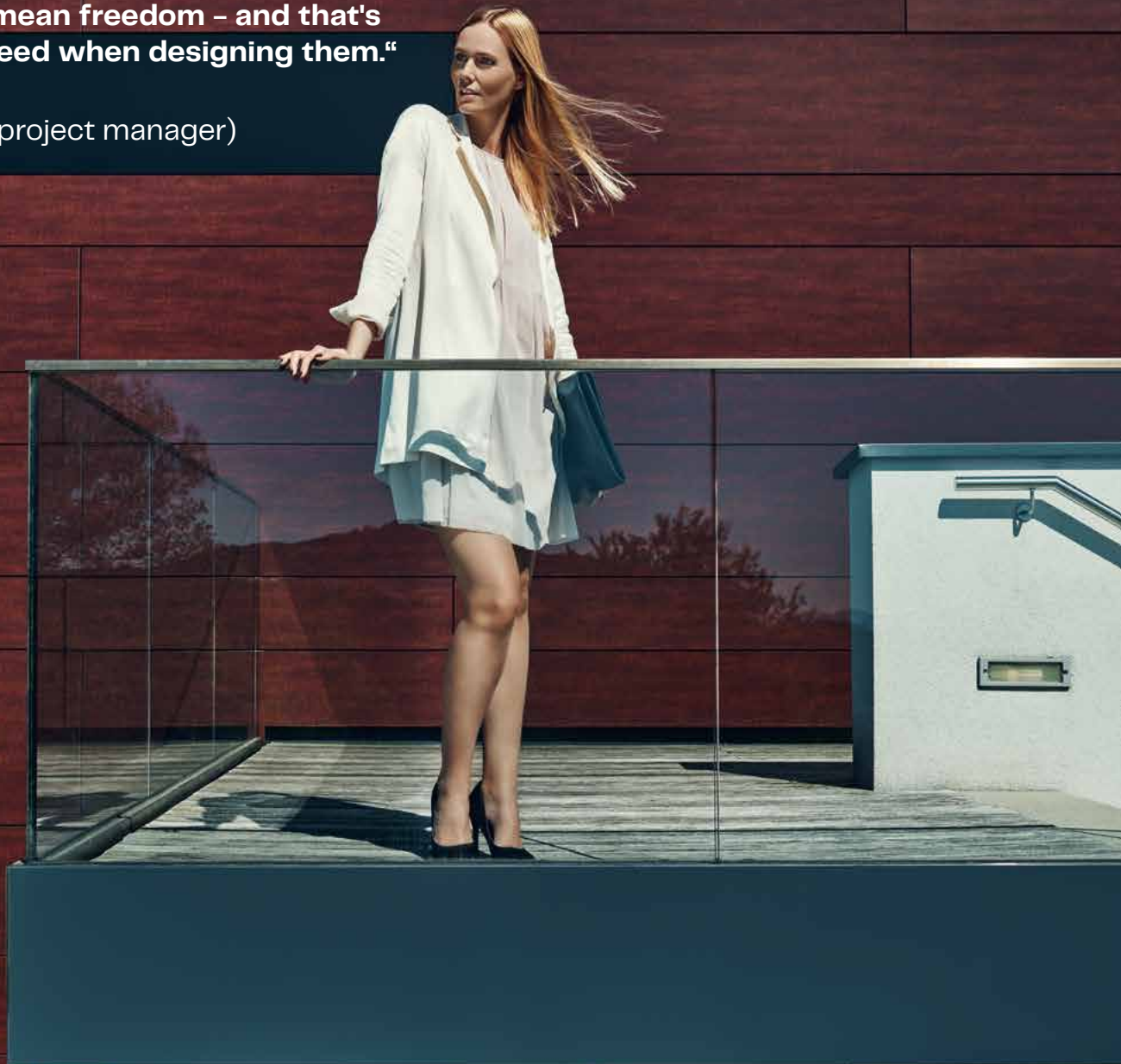

## m.look panels for balconies and railings

### General

During construction and installation, care is to be taken that the material is not exposed to standing water. This means that the panels must always be able to dry out.

Connections of m.look panels to one another always have to be made in the same panel direction. m.look can show deviations from being flat (see EN 438-6, 5.3), and this is to be compensated for by the sub-construction being executed so that it is stable and flat. All connections to other components or to the background must be executed firmly. Elastic intermediate spacers to the sub-construction elements and also between sub-construction elements which permit a greater tolerance than  $\pm 0.5$  mm must definitely be avoided. m.look panels can be mounted with rivets or screws. Due to the material properties of m.look panels, fixed point and sliding points need to be made to mount the panels (see Fig. 8 01).

### Technical notes

The substructure is to be protected against corrosion regardless of the material or system used. Likewise, when selecting the materials to be used, care must be taken to prevent possible contact corrosion. Anchoring elements for installation on walls or for installation of the panels must be suitably dimensioned to withstand the local wind loads and meet the local structural requirements. Verifications are to be submitted to the client. The necessary space for expansion according to the manufacturer's recommendations must be taken into account when installing m.look panels.

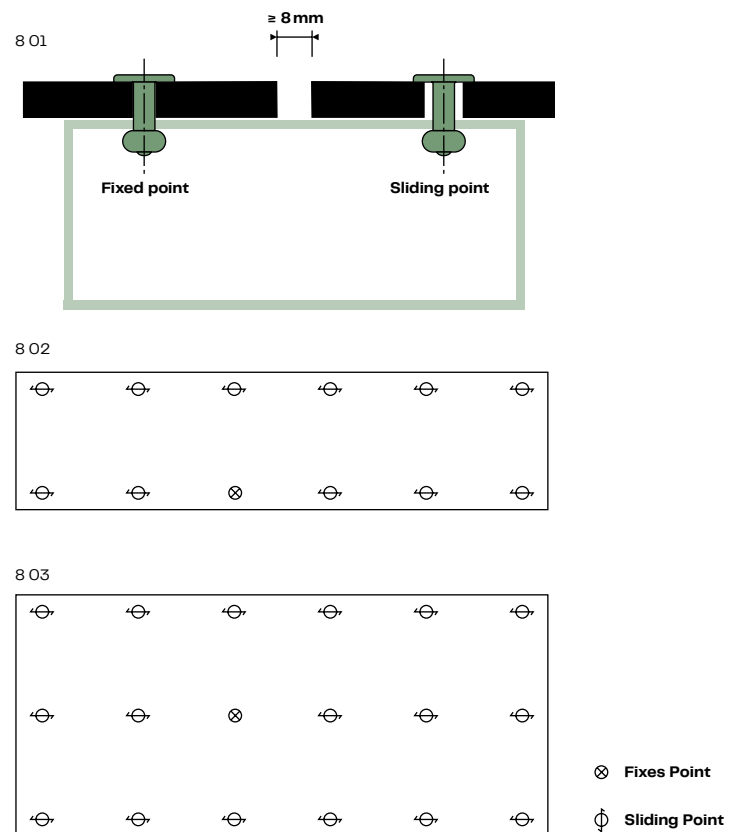

### Sliding Point

The diameter of the drill hole in m.look must be drilled with 8.5 mm. The head of the fastening must be big enough so that the drill hole in the m.look panel is always covered. The fastening is placed in such a way that the panel can move. Rivets are put in place with flexible mouth-pieces. The defined clearance of the rivet head, allows movement of the elements in the drill hole. Clearance + 0.3 mm (Fig. 6 03, p. 15). The centre point of the drill hole in the subconstruction must coincide with the centre point of the drill hole in the m.look panel. Drill with a centring piece! The fastenings should be put in place starting from the middle of panel outwards.

### Fixed Point

Fixed points are used for uniform distribution (halving) of the expansion and shrinkage movements. The diameter of the drill hole in m.look is the same size as the diameter of the fastening.

### Panel Joints

The joints must be made at least 8 mm wide so that changes in size can take place without hindrance.

### Balcony Corners

Especially, in some circumstances, when refurbishing with very uneven subconstructions, it is important to have the front panel protrude about 10 mm in front of the side panel. In this way, inaccuracies can be concealed from the main viewing side.

### Niro/Niro-Blind Rivet

with big head colour lacquered for steel subconstructions.

Rivet sleeve: material-no. 1.4567 (A2)

Rivet pin: steel material-no. 1.4541 (A2)

Pull-off strength of rivet pin:  $\leq 5.8$  KN

Diameter of the drill hole in the m.look panel.

Sliding points: 8.5 mm or as required.

Fixed points: 5.1 mm

Diameter of drill hole in the metal subconstruction: 5.1 mm

When working with metal substructures, be sure to use stainless steel rivets.

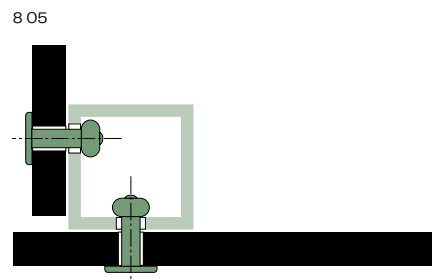
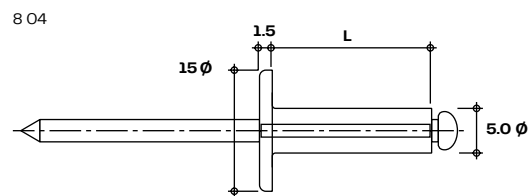

## Balconies and railings

### Fall protection

The non-combustible m.look panel with an A2-s1,d0 classification in accordance with EN 13501-1, was tested at IFT Rosenheim as fall protection in accordance with the ETB guideline "Building Components that Safeguard against Falling" and achieved the rating of suitable for installation area 1 (standard application, office, residential building, etc.) and installation area 2 (crowds, stadiums, train stations, etc.).

### Railings

The variations in the given geometry can also be designed for railings. The railing or handrail heights are to be designed in accordance with local building codes, and in addition it must be ensured that the construction does not create any climbing assistance.

### Balcony system with horizontal belts

Riveted m.look panels. Riveting als described on this page.

Panel thickness	Maximum fastening spacing		Projecting ends E1	Projecting ends E2
	A			
9 mm	A	400 mm	30 - 200 mm	30 - 80 mm
	L	800 mm		

F1 ≤ 120 mm  
F2 ≤ 45 mm

### Balcony system on vertical uprights

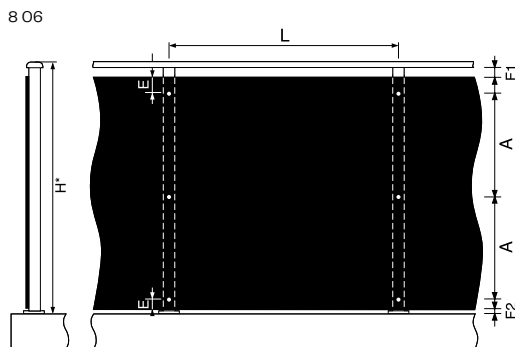

### Balcony system on horizontal uprights

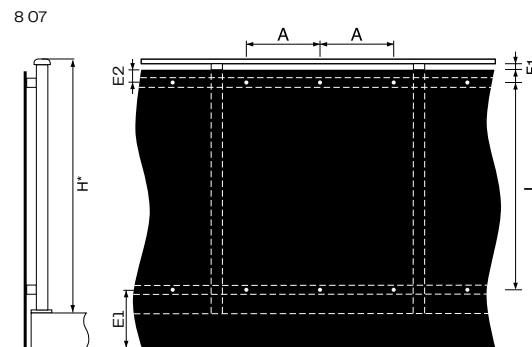

## 9 Balcony divider panels

### General

Divider panels from m.look are used to partition off individual sections of elongated balconies or passageways. The panels are placed perpendicular to the outer wall of the building and affixed to the wall using rivets, just like regular balcony cladding. Depending on the design, the panels extend at maximum from the upper edge of the balcony cladding to the lower edge of the ceiling of the next-lower story of the building.

The hollow substructure is affixed to the reinforced concrete slabs using approved anchor bolts or other mounting parts. As a load-bearing structure, it must meet structural load requirements. The m.look panels are affixed using the same fasteners as for the railing panels. The privacy screen elements must be attached to at least 3 points on each side.

### Fall protection

At IFT Rosenheim, non-combustible m.look panels (with an EN 13501-1 fire rating of A2-s1 d0) were tested for fall protection as required by the ETB guideline entitled "Fall Protection Components." The panels were approved for Installation Case 1 (standard applications, offices, residential construction, etc.) and Installation Case 2 (gatherings of people, stadiums, train stations, etc.).

9 01

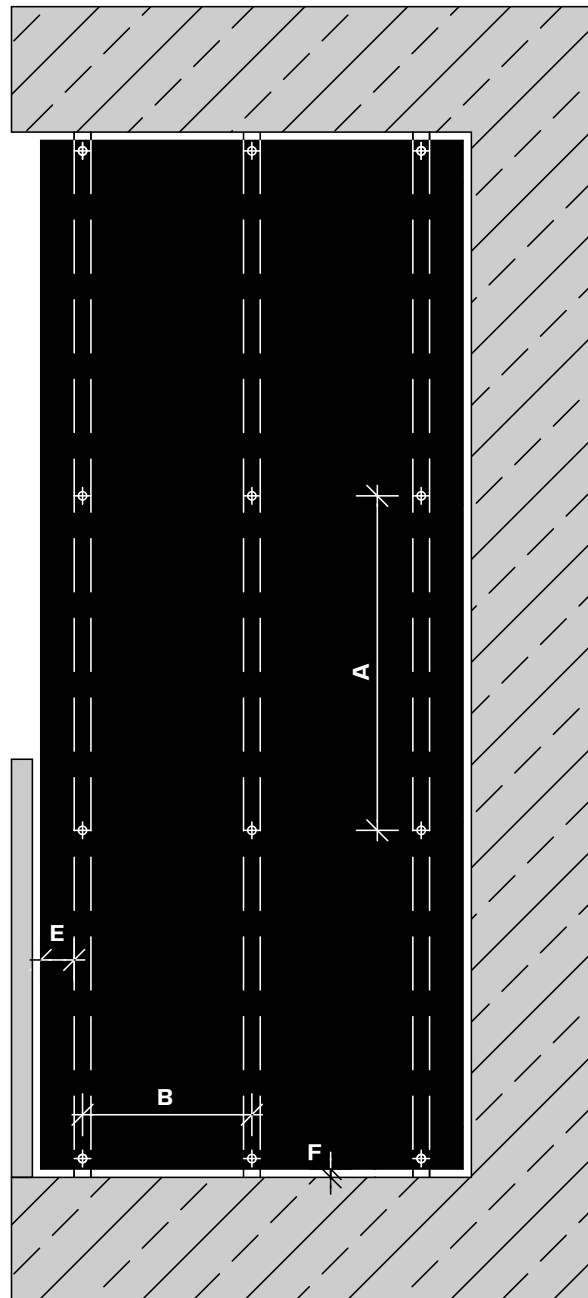

E = Spacing from edge    F ≈ 8.0 mm

To ensure stability, an edge spacing of 30–80 mm must be maintained without fail.



## Wind Loads 9 mm

(A) (CH)

Load chart (wind loads) single span

Load q [kN/m <sup>2</sup> ]	max b [mm]	max a [mm]
0.30	967	967
0.50	851	759
1.00	622	506
1.50	508	405
2.00	440	345
2.50	394	305
3.00	359	275
3.50	333	251
4.00	311	233
4.50	293	217
5.00	278	204

### Fastening spacings

#### for Austria and Switzerland

If the specified axis dimension „b“ is not fully utilized, then the allowable mounting distance „a“ can be calculated as follows (source: Typenstatik m.look Fassadenplatten und m.look Stulpdeckung Dipl.-Ing. Gerald Segeth, Dobel 20.07.19):

$$\text{allow a} = \frac{\text{max b}}{\text{for given b}} * \text{max a}$$

Example:

When installing a double panel with a wind load of 0.5 kN, the following applies: max b = 800 mm and max. a = 573 mm.

If a value of 700 mm is used for „b“ for example, then the maximum allowable „a“ is calculated as follows:

$$\text{allow a} = \frac{800 \text{ mm}}{700 \text{ mm}} * 573 \text{ mm} = 654 \text{ mm}$$

### Caution

The spacing of the fasteners must be modified if the balcony divider panels are being used as a fall protection element (please refer to “Balconies and railings” for spacing information).

(A) (CH)

Load chart (wind loads) multi span

Load q [kN/m <sup>2</sup> ]	max b [mm]	max a [mm]
0.30	1136	673
0.50	880	521
1.00	622	369
1.50	508	301
2.00	440	261
2.50	394	233
3.00	359	213
3.50	333	197
4.00	311	184
4.50	293	174
5.00	278	165

(A) (CH)

Load chart (wind loads) 3-n-panel

Load q [kN/m <sup>2</sup> ]	max b [mm]	max a [mm]
0.30	1137	735
0.50	960	523
1.00	679	369
1.50	554	302
2.00	480	261
2.50	429	234
3.00	392	213
3.50	363	197
4.00	339	185
4.50	320	174
5.00	304	165

The values in the measurement tables are characteristic values. Dimension tables for the wind load range from 0.3 kN/m<sup>2</sup> to 5.0 kN/m<sup>2</sup> are available upon request from the Fundermax Support Team.



D

Load chart (wind loads) single span

Load q [kN/m <sup>2</sup> ]	max b [mm]	max a [mm]
0.30	800	800
0.50	800	800
1.00	622	506
1.50	508	405
2.00	440	345
2.50	394	305
3.00	359	275
3.50	333	251
4.00	311	233
4.50	293	217
5.00	278	204

D

Load chart (wind loads) multi span

Load q [kN/m <sup>2</sup> ]	max b [mm]	max a [mm]
0.30	800	800
0.50	800	573
1.00	622	369
1.50	508	301
2.00	440	261
2.50	394	233
3.00	359	213
3.50	333	197
4.00	311	184
4.50	293	174
5.00	278	165

D

Load chart (wind loads) 3-n-panel

Load q [kN/m <sup>2</sup> ]	max b [mm]	max a [mm]
0.30	800	800
0.50	800	627
1.00	679	369
1.50	554	302
2.00	480	261
2.50	429	234
3.00	392	213
3.50	363	197
4.00	339	185
4.50	320	174
5.00	304	165

## 10 Perforations by m.look

**“Balconies are details. But it’s the details that make the design.”**

(Jonas G., contractor)

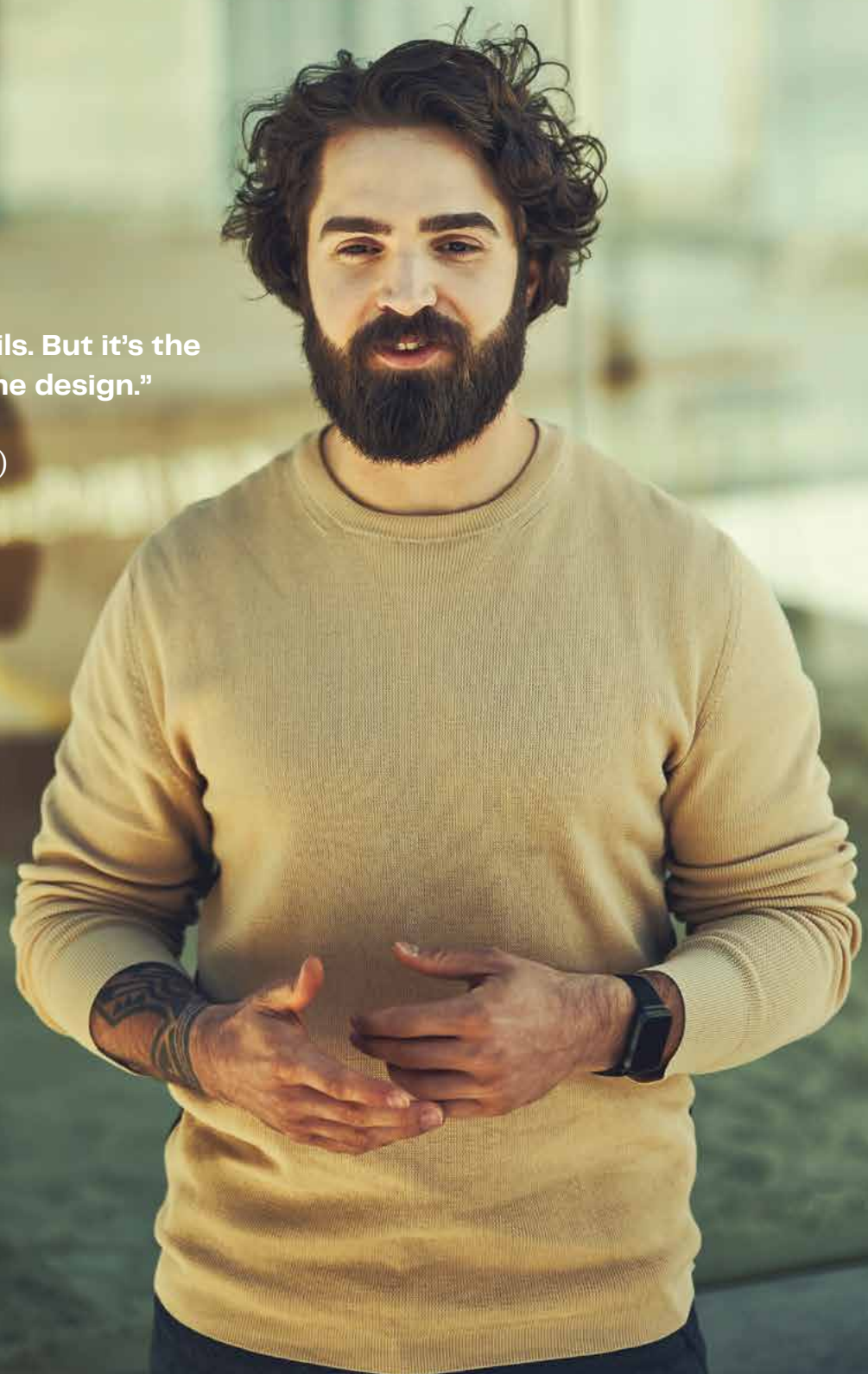

### General

All of the perforations found in m.look panels are decorative. They are available in various designs depending on the desired perforation ratio (ratio of the perforated area to the total surface area). The main thing is to always make sure that the panels can still be mounted without sustaining any damage when being handled carefully. The functionality and safety of the panels when in use also depends on the perforation ratio.

**CAUTION:** Keep in mind that it will take extra time and effort to handle and mount large panels and panels with large-area perforations! Danger of breakage!

Perforated panels do NOT meet the requirements for fall protection for balconies or railing areas. There are no ETB tests for this.

### Working with m.look panels

Large-area perforations can be made in m.look panels using the appropriate diamond-tipped tools or industrial machines. To avoid vibrations that could cause the panel edges to tear away, it is important to affix the panels to a vacuum table before machining. It is also necessary to have a highly efficient vacuuming/cleaning system to collect the saw dust so that there is as little as possible dust accumulation on the panels before stacking or mounting them. Failure to properly clean/remove the dust from the panels prior to mounting can result in significant contamination to the entire application (streak formation after rainfall).

### 7 mm and 9 mm perforated panels from m.look

These panels are suitable for perforations having a diameter of 25 mm–50 mm that can be laid out in a uniform pattern. Keep in mind that the remaining edge width must be at least as wide as the diameter of the perforation. It is also important to allow enough space along the edges to be able to mount the panels.

We recommend a width of at least 80 mm. The distance from the edge of the perforation to the center of the fastener must be at least 40 mm, as shown in the graphic below.

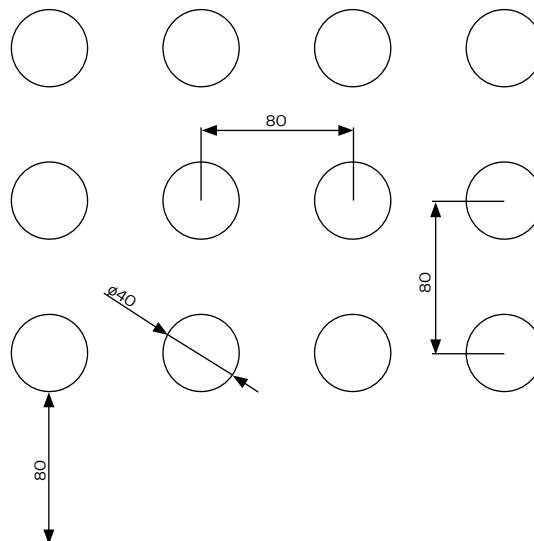

# 11 Recommendations for working

## Guidelines for handling m.look Exterior panels

### Transport and Handling

To avoid damaging the edges and surfaces of the high quality material, it should be handled with care.

Two people are required to safely install panels larger than 2,000 x 1,000 mm. Ensure the panels are kept clean and free of dirt and grit in order to avoid damage to their surfaces.

Fundermax m.look panels must be secured to prevent shifting during transport. The panels must be lifted when they are loaded or unloaded. Do not pull or push them over the edge of the stack!

Maximum weight of the pallets: 1,800 kg (gross)

m.look panels can also be delivered with a protective film upon request.

Protective films must always be removed from both sides at the same time. The protective film must not be exposed to heat or direct sunlight.

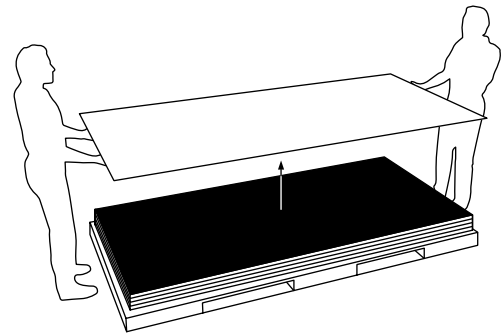

11 01

### Pallet Handling

When transporting and lifting the pallets it is essential to use an appropriate forklift with wide forks or a crane with lifting points uniformly distributed along the length of the pallet. Do not stack pallets of cut panels.

### Storage and air conditioning

Fundermax m.look panels should always be left in the original packaging. The panels should be stacked horizontally on a flat, stable and padded raised surface. If this is not possible, the panels can be temporarily stored as shown in Fig. 11 02.

The panels must lie completely flat. After removing the panels, the original packaging should be closed again.

Cover plates must always be left on the stack (see Fig. 11 03). The top cover should be weighted down. The same applies, in principle, for cut-panel stacks.

Incorrect storage can lead to permanent deformation of the panels.

Fundermax m.look panels should to be stored in closed rooms under normal climatic conditions, temperature about 15°C - 25°C and relative humidity at about 40% - 60%. Climate differences on the two surfaces of a panel are to be avoided.

### Hint for final cleaning

Please ensure that foreign substances (e.g. drilling and machine oils, greases, adhesive residues, etc.) that soil the surface of the m.look panels during storage, installation and use are removed immediately without leaving any residue.

We recommend using non-greasy sunscreens (e.g. Physioderm Physio UV 50 Spray), as soiling with conventional sunscreens is often impossible to remove completely even when cleaned immediately. No responsibility will be accepted for any complaints regarding color, gloss and surface of the panels should these recommendations fail to be observed.

For details on how to properly clean m.look panels, see page page 48.

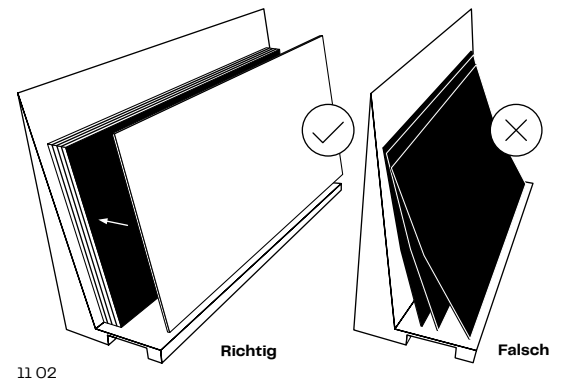

11 02



11 03

## Machining m.look Panels

### General

We are happy to cut the panels to your specifications, including interior cutouts. For finishing cuts, please refer to the information below.

The surface of the Fundermax m.look panel consists of double hardened resins and is therefore very durable. Finishing cuts on site must be performed with diamond-tipped tools. Sharp blades and smooth running tools are required to ensure proper machining. Improper handling or the use of unsuitable tools may result in the breaking, splintering or chipping of the decorative side of the panel. Tables should be smooth and preferably without joints to ensure that no shavings can get stuck there where they might damage the surface of the panel. A circular saw can be used for interior cutouts.

All the machining equipment should be designed with sealed bearings. In order to avoid chipping the edges, it is necessary to bevel them with a sanding block (45 degrees, approx. 0.25 mm).

### Safety Precautions

This is a list of the recommended personal protective equipment (PPE). The appropriate personal protective equipment required by health and safety regulations (long-sleeved work clothes, safety shoes, hair net, etc.) should always be worn when working with Fundermax m.look panels.

**Please be sure to observe the standard safety rules when machining m.look panels and to wear proper safety gear such as gloves, long clothing, protective goggles, ear protection and dust protection.**



### Protective Goggles

When machining Fundermax m.look panels with tools that create shavings or chips, please be sure to wear tightly fitting protective goggles.



### Dust Protection

Machining Fundermax m.look panels must be performed with suitable dust extraction to keep the work place dust free. Dust from machining the panels may lead to mechanical irritation of the skin and mucous membranes. Adequate respiratory protection (e.g. disposable dust mask P1) must be worn when machining the panels.



### Ear Protection

When machining Fundermax m.look panels the noise levels may exceed 80dB(A). Please be sure to always wear adequate ear protection when machining m.look panels.



### Gloves

Non-beveled cut edges are sharp. There is a risk of injury. It is recommended to wear category II protective gloves with at least category II cut resistance when handling freshly cut Fundermax m.look panels.

### Cutting with handheld tools

Finely toothed handheld saws are suitable for finishing cuts on site. Sharp blades and smooth functioning are essential to ensure the faultless machining of materials.

For straight cuts with handheld circular saws, a stop bar or guide rail should be used. Diamond-tipped saw blades should always be used. nn-System saw blades from Leuco are recommended for processing Fundermax m.look panels with a handheld circular saw.

Incorrect handling and unsuitable tools result in breaking-off, splintering and chipping of the decorative side.

### Edge processing with handheld machines

Electric hand routers can be used to mill bevels. To protect the Fundermax m.look panel surface area, the supporting surface of a hand router should be covered with panel parts, for example (no felt). Milling shavings should be carefully removed.

We recommend hard metal tipped milling cutters. To improve tool functioning, height-adjustable milling cutters are preferable.

### Edge processing by hand

Files are suitable for the finishing of edges, with the file direction moving from the decorative side to the core. Fine files or sandpaper with a grain of 100-150 can be effective for treating broken edges or bevelling.

### Drilling

Solid carbide spiral or dowel drill bits should be used. At machining centers it is recommended to use an insert in the main spindle instead of in the drilling head at a speed of 2,000 – 4,000 min<sup>-1</sup> and feed speed of 1.5 – 3 m/min.

The exit speed of the drill must be selected such that the surface of the m.look panel is not damaged. Just before the drill exits the rear side of the panel in its full diameter, the feed rate should be reduced by 50%. When drilling holes all the way through the panel, be sure to use a suitable base to ensure there is sufficient counter-pressure.



11 04



11 05



11 06

- 11 04 Leitz-drill bit 10 mm
- 11 05 Leitz-drill bit HW-solid, Z2
- 11 06 MBE VHM facade drill bit

## General requirements on machining centres

### Processing m.look panels in machining centres

#### General

For machining centres, the heavy-duty, reinforced glass fibre, predominantly mineral, non-flammable core places high demands on the machining process as regards handling, bearing seals, extraction and the final cleaning of panels on the machine table. Since a panel material with A2 fire classification cannot be thermally recycled, care must be taken to separate dust and wood chips in the extraction process. Proper disposal of residual dust and panels is compulsory.

The deployment of standard machines not suitably adapted as regards appropriately dimensioned seals, bearings and drive capacities is not recommended in the processing and machining of m.look.

Without taking the precautions outlined, machining of the resistant core is likely to result not only in significantly reduced tool service life, but also greater wear on machine parts exposed to high cutting pressure and dust.

Processing with machines for which constant cutting parameters cannot be guaranteed is only suitable for some finishing cuts where reworking is possible in case of tears or edge chipping.

### Requirements on the machine park

To ensure the industrial processing and machining of m.look panels, at least the following machine parameters must be met:

- Product handling with a suction handle and sufficiently dimensioned stacker forks
- Formatting and drill holes via CNC or nesting systems
- Drive power of milling spindle  $\geq 15$  kW with true running tool fitting
- Dust-resistant bearing seals and guides
- Vacuum table for format 3,500 x 1,330 mm
- Diamond-tipped milling cutters (e.g. Leuco high performance end mill DP 12 mm (Z 2+1))
- Machine extraction output  $\geq 10,000$  m<sup>2</sup>/h
- Separate collection of dust and residue
- Material disposal by means of landfill or industrial waste
- Antistatic final cleaning of panels with Wandres brush  $\geq 1,000$  m<sup>2</sup>/h



## Cutting and Milling of Compact Panels – Recommendations for Processing Problems

### Fixing panels on a machine table

There are basically two ways to fix or tension Max Compact Exterior panels on machine tables depending on the type of processing to be performed:

#### a.) Fixing by means of suction cups

When milling to size or edging both sides of a panel section, it is recommended to fix the panel in place using suction cups at specific points.

Notice: The proper distance between the suction cups must be observed!

#### b.) Fixing by means of MDF protective boards

When milling to size, edging one side, making perforations or free-form milling a panel section, it is recommended to fix the panel in place using MDF protective boards (protective boards can be used several times).

The following applies for both options: It must be ensured that the suction cups provide sufficient holding power for the work to be performed. If the suction cups do not provide sufficient fixing or tensioning power, the suction cup seals (e.g. the sealing rings) must be checked.

#### Spacing of the suction cups

As a rule, the material being processed should not be subjected to any vibrations. Therefore, it is important that the suction cups are placed at an appropriate distance from the freely protruding panel edge based on the thickness of the panel.

The following applies: the more suction cups and the smaller the distance from the free protruding edge of the panel, the cleaner the milling pattern. As a rule of thumb, suction cups should be placed in the area to be processed in a grid of max. 300 mm with a maximum distance from the free protruding edge of the panel of no more than 30 mm. The best results are achieved by using an MDF protective board (e.g. 19 mm thick), as this enables a full-surface fixing of the m.look panel on the machine table with suction cups.

#### Choice of machining tool

Generally speaking, Max Compact Exterior panels can be machined with solid carbide (VHM) and diamond (PCD) milling tools. The basic prerequisites for a clean milling pattern and a long service life are vibration-free tool holders and spindles. NOTE: The ball bearings must be properly maintained!

Diamond tools have proven particularly suitable for processing a large amount of panels or a high number of running meters. Smooth-running milling cutters with a shank diameter of min. 10 mm in combination with straight continuous DIA cutting edges (2+1 knife) are especially suitable for format milling.

It is essential that the feed rate and the cutting speed be adjusted for the specific job and cutter based on the material being processed. We recommend always consulting the tool supplier first.

#### Clamping system of the milling tool

It is essential that the spindle be centered in the chuck to ensure the smooth running of the milling cutter. The more centered and play-free the milling cutter can be clamped in place, the better the result. Most machines are equipped with common tool holders such as collets, hydro grips or shrink chucks.

For the professional CNC machining of larger jobs, a Hydro Grip tool holder or shrink chuck is recommended as they guarantee the best tool clamping. It is important to ensure the proper maintenance of all moving parts such as plain or ball bearings in order to avoid vibrations in every direction!

#### Extraction

The extraction or the extraction power must be adjusted accordingly for the material being processed to ensure that all the shavings are optimally removed.

If the extraction is not strong enough, there is a risk of heat development. This is due to shavings that remain between the cutter and the panel edge. High friction occurs at this point because the cutter can not eject the material any further. This can lead to burn marks on the panel edge.

#### CNC machining by Fundermax

Fundermax has their own machining center – Compact Elements. We are happy to machine Max Compact Interior, Max Compact Exterior, Max HPL and m.look panels to your specifications. Simply contact our customer service center for more information.

## 12 Recommendations for mounting

**„A perfect product needs  
to be installed perfectly.“**

(Katrin E., carpenter)





## Installation of m.look panels

### General

Anchoring elements for affixing the substructure to walls and the installation of panels must be suitably dimensioned to withstand local wind conditions and meet local structural requirements; the ordering party must be provided with verification of this.

Please note that the installation of m.look Exterior panels must take account of the necessary space for expansion. To ensure the tension-free movement of m.look Exterior panels, the joint formation must be at least 8 mm.

In Germany, joint formation is limited to 8 mm in line with technical approval no. Z-10.3-711. The recommended joint spacing can be achieved with spacers (Fig. 12 02); we recommend using smooth spacers.

Avoid placing the panels on hard, stony surfaces. Suction handles can be used to place panels in the correct mounting position (Fig. 12 03 and 12 04).



12 01

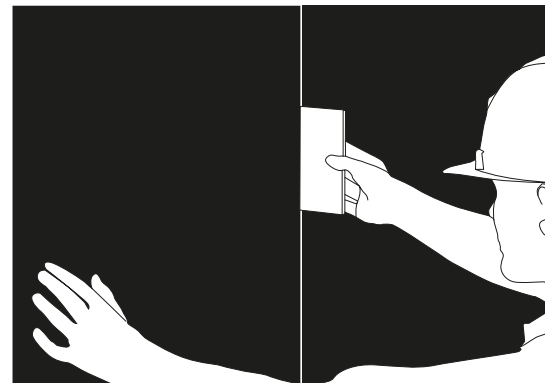

12 02

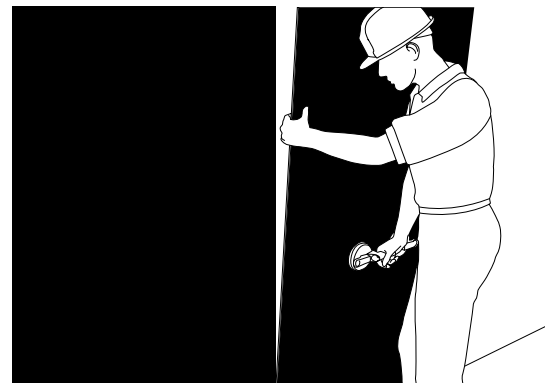

12 03

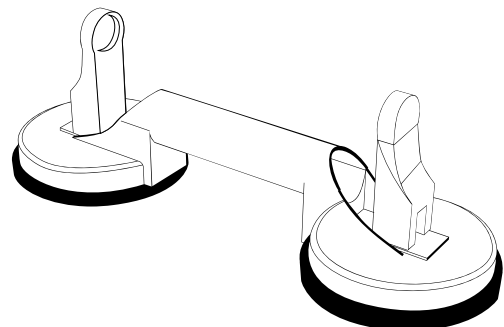

12 04

- 12 01 Aluminium Substructure
- 12 02 Spacer for ensuring proper joint space
- 12 03 Place panels with suction handles
- 12 04 Suction handle

**Element sizes**

For installation by hand, the recommended m.look panel size is 2,000 x 1,000 mm. This size panel can easily be installed by two people. We recommend carrying the panel vertically.

For larger sizes, we recommend installing the panels with lifting equipment.

Fundermax has its own processing centre: Compact Elements. We are happy to provide prefabricated panels; please contact our customer service centre for details.

**Cutting**

To perform optimal final cuts, we recommend using a circular saw with guide rail and extraction (Fig. 12 05 and 12 06). Please take note of the machining recommendations (pages 36–41).

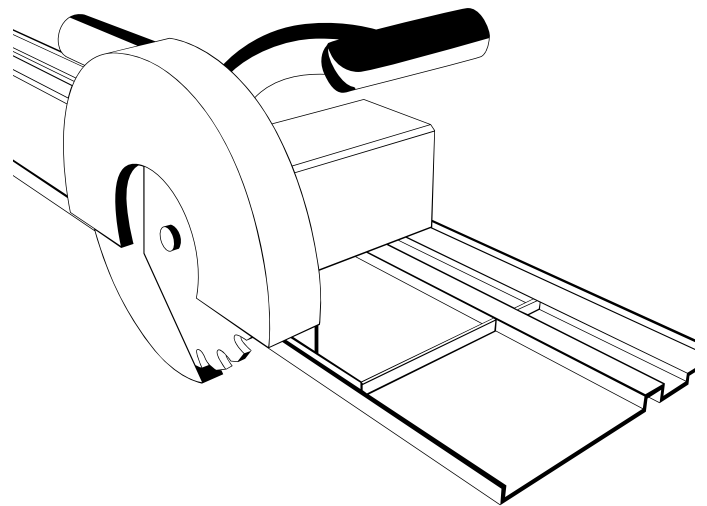

12 05

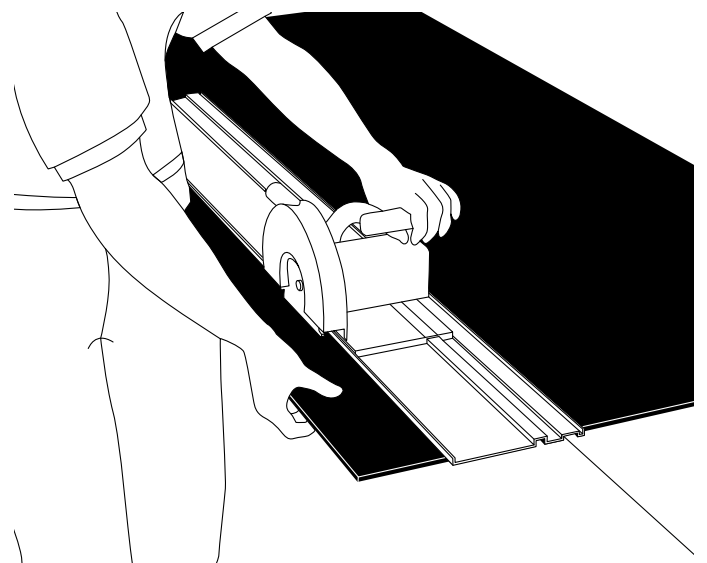

12 06

### Drilling

A drill or cordless screwdriver can be used to pre-drill m.look Exterior panels (Fig. 12 07 and 12 08). We recommend a carbide drill or VHM facade drill bit (Fig. 11 06, p. 39) from MBE for drilling.

The centre of the drill hole in the substructure must coincide with the centre of the drill hole in the m.look panel; suitable drill guides (MBE, SFS centring tool) should be used (Fig. 12 12). We recommend diamond-tipped core drills for making drill holes (Fig. 12 10).

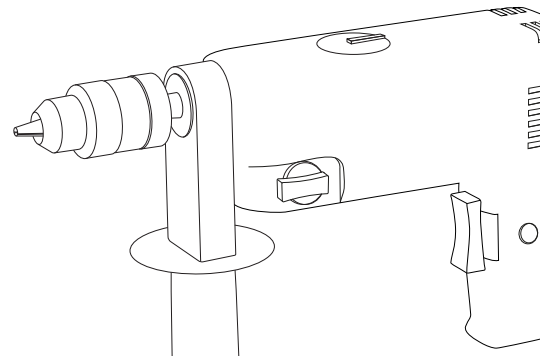

12 07

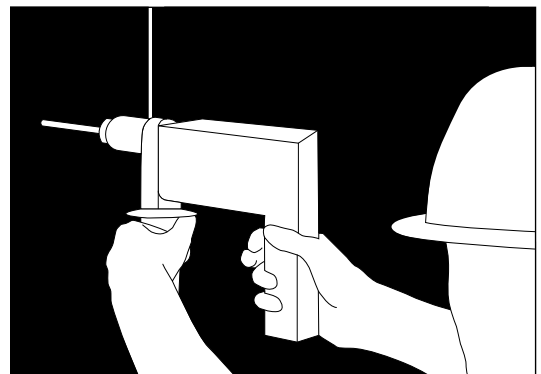

12 08

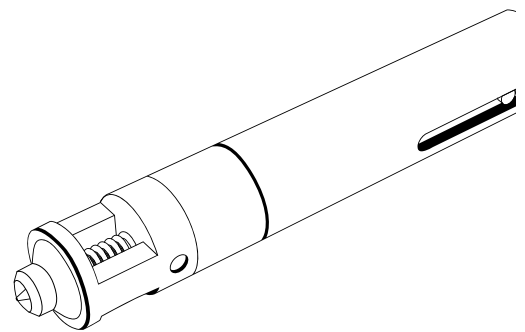

12 09

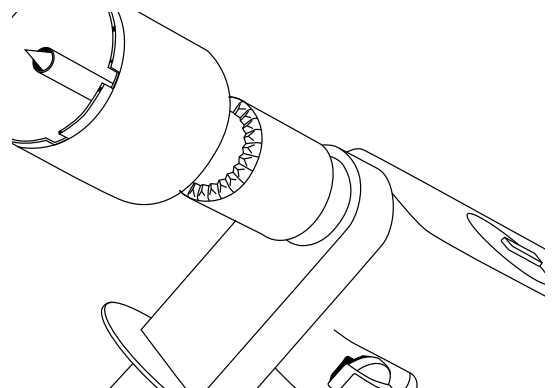

12 10

- 12 07 Drill
- 12 08 Pre-drill panel
- 12 09 Drill centering tool
- 12 10 Diamond-tipped core drill

### Rivets

Rivets are placed using an electric rivet gun/ calliper (Fig. 12 11).

The drill hole diameter for the fixed point in the m.look Exterior panel is 5.1 mm.

The drill hole diameter for the sliding points in the m.look Exterior panel is 8.5 mm. The head of the fastening must cover the drill hole.

The sliding point is placed in such a way that the panel can move. Rivets must be centred and put in place with a flexible mouthpiece (Fig. 12 12 and 12 13). The flexible mouthpiece ensures a distance of 0.3 mm between the panel and the rivet head (Fig. 12 14).

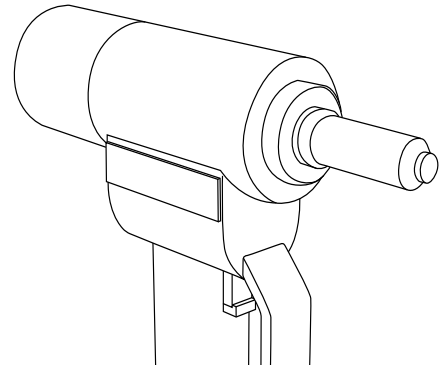

12 11

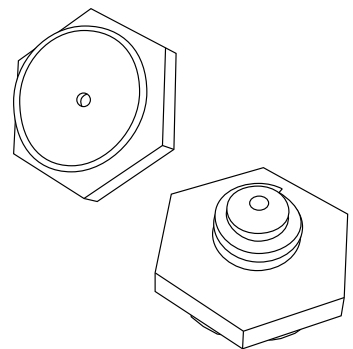

12 12

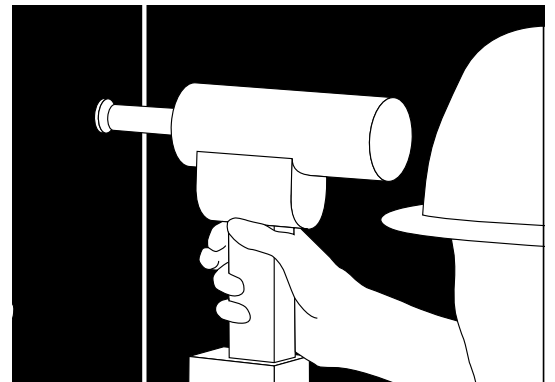

12 13

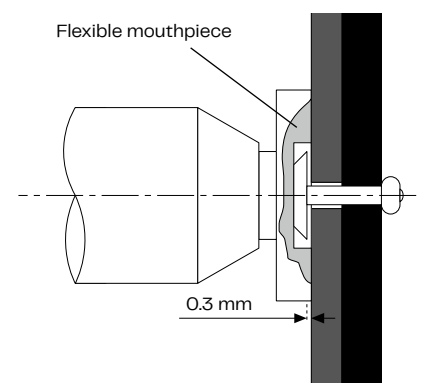

12 14

- 12 11 Rivet gun/caliper
- 12 12 Flexible mouthpiece
- 12 13 Sliding point with flexible mouthpiece
- 12 14 Flexible mouthpiece (clearance 0.3 mm)

# 13 Cleaning



**„Flawlessness is  
the most beautiful goal.“**

(Matteo V., architect)



## Cleaning steps for m.look panels

For removing dust vacuum clean the surface and wipe off residual dust with a clean, dry cotton cloth. Finally wipe with a damp cloth. For removing any other contamination please follow the cleaning steps until the desired cleaning effect.

### Step 1

Clean the surface with clean hot water and a soft sponge (DO NOT scrub the surface with the „green“ side of the sponge), a soft cloth or a soft brush (e.g. a nylon brush).

### Step 2

If there is any dirt that can not be removed with a sponge and warm water, you can use normal, non-abrasive household cleaners such as dishwashing detergent (Palmolive, Fairy) or glass cleaner (Ajax, Frosch). Perform a final cleaning.

### Step 3

If there is still any dirt that can not be removed, use a solution of soft soap and water (1:3). If the dirt is particularly stubborn, let it soak for a while. Perform a final cleaning.

### Step 4

If any dirt is still remaining, you can repeat step 1 using organic solvents (e.g. acetone, ethyl alcohol, lacquer remover, turpentine).

If there is any dirt that still can not be removed, you can try scraping it off physically. Caution: To avoid scratching the panels, use a plastic or wooden spatula. Perform a final cleaning.

### Step 5 (for Adhesives, Paints, Sealants or Silicone Residues)

Rub the surface with a soft dry cloth or a soft dry sponge. If the material still can not be removed, use silicone remover (for example from Molto) or ask the manufacturer of the adhesive for the ideal cleaning agents.

Caution: Hardened adhesive, 2K paints, foams and sealant can NO LONGER be removed.

### Step 6

If the panel is still dirty you can repeat step 1, using liquid cleaner with polishing chalk (CIF, ATA). Only use liquid cleaner with polishing chalk sparingly! For extremely stubborn lime deposits you can also use acidic cleaning agents (e.g. 10% vinegar or citric acid). Perform a final cleaning.

### Final cleaning

Completely remove any remaining detergent to avoid streaking. Finally, wash off with clean water and dry. Wipe the surface dry with an absorbent cloth or paper towel.

When cleaning with solvents: Observe the safety regulations! Always work with an open window! Do not work near any open flames!

# 14 Accessories/Suppliers

## Substructure:

### Austria

ALLFACE Befestigungstechnologie GmbH & CoKG  
Aredstraße 29/Büro 222  
A-2544 Leobersdorf  
Tel: +43 (0)2256/625 18  
Fax: +43 (0)2256/625 18 18  
E-mail: office@allface.com  
www.allface.com

Hilti EUROFOX GmbH  
Gewerbepark 10  
A-2810 Lanzenkirchen  
Tel: +43 (0) 2627 42400-0  
Fax: +43 (0) 2627 42400-40  
www.eurofox.com

SLAVONIA BAUBEDARF  
Hauffgasse 3-5 D/G  
A-1110 Wien  
Telefon: +43 (0) 1/769 69 29  
Fax: +43 (0) 1/769 69 27  
www.slavonia.com

### Germany

BWM  
Dübel und Montagetechnik GmbH  
Ernst-Mey-Str. 1  
D-70771 Leinfelden-Echterdingen  
Tel: +49 (0) 711 / 90 313-0  
Fax: +49 (0) 711 / 90 313-20  
www.bwm.de

Systema DWS Pohl GmbH  
Margarete-Steiff-Str. 6  
D-24558 Henstedt-Ulzburg  
Tel: +49 (0) 4193 / 99 11-40  
Fax: +49 4193 / 99 11-49  
www.pohl.net.com

NAUTH SL Fassadentechnik GmbH  
Weinstr. 68 b  
D-76887 Bad Bergzabern  
Tel: +49(0) 6343 7003-0  
Fax: +49 (0) 6343 7003-20  
www.nauth-sl.de

### France

L.R ETANCO  
38/40 Rue des Cormiers - BP 21  
78401 CHATOU CEDEX (France)  
Phone: +.33.1.3480.5288  
Fax: +.33.1.3480.5240  
www.etanco.fr

### Switzerland

WAGNER SYSTEM AG  
Werkstrasse 73  
CH-3250 Lyss  
Tel: +41 32355 2722  
Fax: +41 32355 2837  
www.wagnersystem.ch

## Fastenings: (mechanical)

### Austria

EJOT AUSTRIA GmbH  
Grazer Vorstadt 146  
A-8570 Voitsberg  
phone +43 3142 2 76 00-0  
fax +43 3142 2 76 00-30  
E-mail: info@ejot.at  
www.ejot.at

### Germany

SFS Intec GmbH, Division  
Construction  
In den Schwarzwiesen 2  
D-61440 Oberursel  
Tel: +49 6171 7002-0  
Fax: +49 6171 7002-55  
www.sfsintec.de

MBE GmbH  
Siemensstraße 1  
D-58706 Mendene  
Tel: +49 (0)2373 17430-0  
Fax: +49 (0)2373 17430-11  
www.mbe-gmbh.de

### Switzerland

SFS intec AG (Headquarters)  
Rosenbergsaustrasse 10  
CH-9435 Heerbrugg  
Tel: +41 71 727 62 62  
Fax: +41 71 727 53 07  
E-Mail:gmi.heerbrugg@sfsintec.biz  
www.sfsintec.biz

## Profiles/Accessories:

### Austria

Protektor Bauprofile GmbH  
Hosnedlgasse 12  
A-1220 Wien  
Tel: +43 (0)1 259 45 00-0  
Fax: +43 (0)1 259 45 00-19  
www.protektor.com

### Germany

Protektorwerk  
Florenz Maisch GmbH & Co.KG  
Viktoriastraße 58  
D-76571 Gaggenau  
Tel: +49 (0)7225 977-0  
Fax: +49 (0)7225 977-111  
www.protektor.com

### France

PROTEKTOR S.A. BATI-PROFIL  
Rue Pasteur Prolongée  
F-94400 Vitry sur Seine  
Tel: +33 (0) 1 / 55 53 17 50  
Fax: +33 (0) 1 / 55 53 17 40

This brochure is intended to provide you with technical information about the m.look panel for outdoor applications. Examples of possible applications can be found in the m.look brochure and at [www.fundermax.com](http://www.fundermax.com).

If you have any questions that are not answered in this brochure, please contact our application engineering ([support@fundermax.biz](mailto:support@fundermax.biz)). We are happy to help.

m.look – for you to create.

**Exclusion of Liability**

The information made available in this document are exclusively for purposes of general information. Not all of the systems mentioned and shown in this document are appropriate or suitable for all areas of application. All customers and third parties are obligated to inform themselves thoroughly about Fundermax products, including their suitability for certain purposes. We explicitly recommend that you and other users of this document seek out independent expert advice on adherence to local planning and use requirements, applicable laws, regulations, standards, guidelines and testing standards. Fundermax accepts no liability in connection with the use of this document. The general sales conditions of Fundermax GmbH in the current version (available at [www.fundermax.com](http://www.fundermax.com)) shall apply for all of our oral as well as written statements, offers, sales quotes, sales, deliveries and/or contracts and all related activities.

**Copyright**

All texts, photographs, graphics, and audio and video files are protected by copyright law as well as by further intellectual property laws and may not be duplicated, altered or used on other websites for purposes of business, etc.

**Fundermax Deutschland GmbH**

Mundenheimer Weg 2  
D-67117 Limburgerhof  
infogermany@fundermax.biz  
www.fundermax.com

**Fundermax France S.a.r.l.**

3 Cours Albert Thomas  
F-69003 Lyon  
T +33 (0)4 78 68 28 31  
infofrance@fundermax.biz  
www.fundermax.com

**Fundermax India Pvt. Ltd.**

Sy. No. 7, Honnenahalli, Doddballapur Road,  
IND-Yelahanka Hobli, Bangalore - 560064  
T +96113 99211  
officeindia@fundermax.biz  
www.fundermax.in

**Fundermax Italia s.r.l.**

Viale Venezia 22  
I-33052 Cervignano del Friuli  
infoitaly@fundermax.biz  
www.fundermax.com

**Fundermax North America, Inc.**

9401-P Southern Pine Blvd.  
Charlotte, NC 28273, U.S.  
T +1 980 299 0035  
office.america@fundermax.biz  
www.fundermax.us

**Fundermax Polska Sp. z o.o.**

ul. Rybitwy 12  
PL-30-722 Kraków  
T +48 (0)12 65 34 528  
infopoland@fundermax.biz

**Fundermax Swiss AG**

Industriestrasse 38  
CH-5314 Kleindöttingen  
T +41 (0)56 268 83 11  
infoswiss@fundermax.biz  
www.fundermax.com

**Fundermax GmbH**

Klagenfurter Straße 87-89, 9300 St. Veit/Glan, Austria  
T: +43 (0)5 9494-0, F: +43 (0)5 9494-4200  
office@fundermax.at  
www.fundermax.com

